

Occhio

io verticale VOLT

Montageanleitung
Mounting instructions

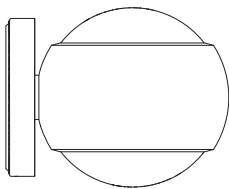

VOLT

Inhalt / Contents

Sicherheitshinweise	04	Safety precautions	05
Produktbeschreibung	06	Product description	07
Linse und inserts einsetzen	09	Inserting lens and inserts	09
Montage io verticale VOLT	15	Mounting io verticale VOLT	15
up / down		control up / down	
zusammen steuern	19	simultaneously	19
up / down		control up / down	
getrennt steuern (optional)	21	individually (optional)	21
Demontage io verticale VOLT	25	Remove io verticale VOLT	25
Steuerung mit der Occhio air App (optional)	29	Control using the Occhio air app (optional)	29
Steuerung mit dem Occhio air controller (optional)	37	Control using the Occhio air controller (optional)	37
Anhang	41	Appendix	41
Pflegehinweise	42	Care instructions	42
Info & Kontakt	43	Information & contact	43
Technische Daten	44	Technical data	45

Sicherheitshinweise

Lesen Sie die Montage-/Gebrauchsanweisung sorgfältig durch, bevor Sie die Leuchte installieren. Beachten Sie die Sicherheitshinweise in dieser Anleitung genau und bewahren Sie die Anleitung auf.



Dieses Zeichen macht Sie auf eine gefährliche Situation aufmerksam, die eine schwere Verletzung oder den Tod nach sich ziehen kann, wenn sie nicht beachtet wird. Es macht Sie zudem auf mögliche Sachschäden und andere wichtige Informationen in Verbindung mit diesem Produkt aufmerksam.



Die Montage von Elektrokomponenten darf nur von qualifiziertem Fachpersonal durchgeführt werden. Reparaturarbeiten dürfen nur von autorisiertem Fachpersonal oder dem Hersteller durchgeführt werden. Vor allen Arbeiten an der Leuchte (Installation, Reinigung etc.) diese unbedingt vom Stromnetz trennen.



Dieses Zeichen macht Sie auf Situationen aufmerksam, bei denen Sie direkt in das Licht der LED blicken könnten. Dies kann zu Nachbildern und bei längerer Dauer zu Schädigungen der Augen führen.



Sicherheitsabstand zu brennbaren Objekten einhalten: 20 cm!



Dieses Zeichen macht Sie auf heiße Oberflächen aufmerksam, deren Berührung Verbrennungen zur Folge haben können.

Achtung: Die Oberfläche der Leuchte kann nach längerer Betriebsdauer heiß sein! Vor allen Arbeiten an der Leuchte (Montage usw.), Leuchte immer ausschalten und mindestens 30 Minuten abkühlen lassen. Nur zur Installation außerhalb des Handbereichs vorgesehen.

Safety precautions

Read through the mounting/ use instructions carefully before installing the luminaire. Follow the safety precautions in these instructions closely and keep the instructions in a safe place.



This symbol warns you of a dangerous situation which could lead to serious injury or even death if the instructions are not observed. It also draws your attention to possible material damage and provides other important information in connection with this product.



The assembly and installation of electrical components must be carried out only by qualified personnel. Repairs must be carried out only by authorised, qualified personnel or the manufacturer. Before performing any work on the luminaire (installation, cleaning, etc.), it must be disconnected from the mains supply.



This symbol draws your attention to situations in which you could look directly into the light of the LED. This may cause an after-image effect and may result in damage to the eyes if you look at the light directly for prolonged periods.



Maintain the minimum safety distance from flammable materials: 20 cm.



This symbol warns you of hot surfaces, which could cause burns if touched.

Caution: When used for prolonged periods, the surface of the luminaire can become hot. Before performing any work on the luminaire (fitting the luminaire etc.), always switch the luminaire off and let it cool for at least 30 minutes. Only for installing in a position which is out of arm's reach.

Produktbeschreibung

LED Wandstrahler mit beidseitigem Lichtaustritt, kugelförmigem Kopf und Linsenoptik. Die Leuchte ist frei drehbar (mit Anschlag), die Lichtwirkungen sind durch optionale inserts jederzeit über einen einfachen Mechanismus veränderbar, dichroitische Farbfilter zusätzlich einsetzbar. Oberflächenkombinationen konfigurierbar.

Version für Aufputzmontage, Anschluss an 230V AC/50Hz Netzspannung, Leistung 18W oder 13W*, dimmbar via Phasenabschrittdimmer**. VOLT light engine wechselbar.

Weitere Versionen: io alto v, io giro, io giro doppio, io piano, io piano v

* Version chrom glanz, rose gold, bronze

** Liste kompatibler Dimmer:
www.occhio.com/dim, Phasenabschrittdimmer

Product description

LED wall spotlight with double-sided light output, spherical head and lens optics. The light is freely rotatable (with stop), the lighting effects can be changed at any time through optional inserts using a simple mechanism, dichroic colour filter can be additionally inserted. Surface combinations can be configured.

Version for mounting on plaster surfaces; connection to 230 V AC / 50 Hz mains voltage; power 18 W or 13 W*, dimmable via trailing-edge phase-cut dimmer**. The VOLT light engine is replaceable.

Other versions: io alto v, io giro, io giro doppio, io piano, io piano v

* Version shiny chrome, rose gold, bronze

** For a list of compatible dimmers, see www.occhio.com/dim_en, trailing-edge phasecut dimmer

Linse und
inserts
einsetzen

Inserting lens
and inserts

Linse und inserts einsetzen

Inserting lens and inserts

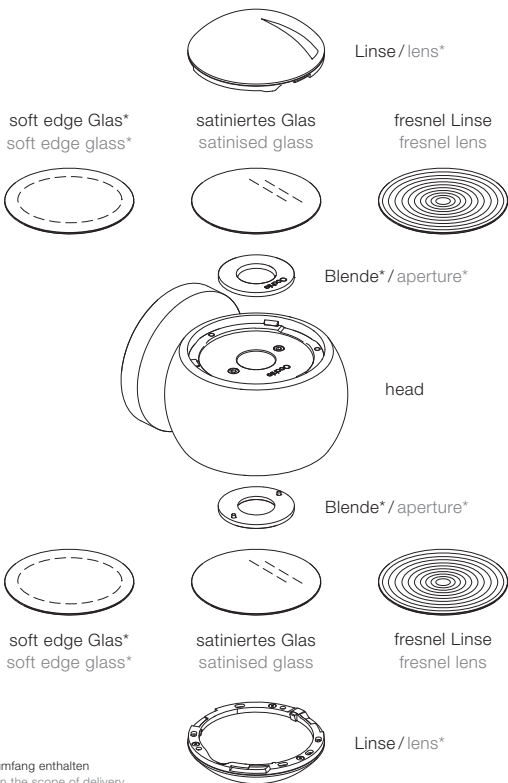

* Im Lieferumfang enthalten

* Included in the scope of delivery

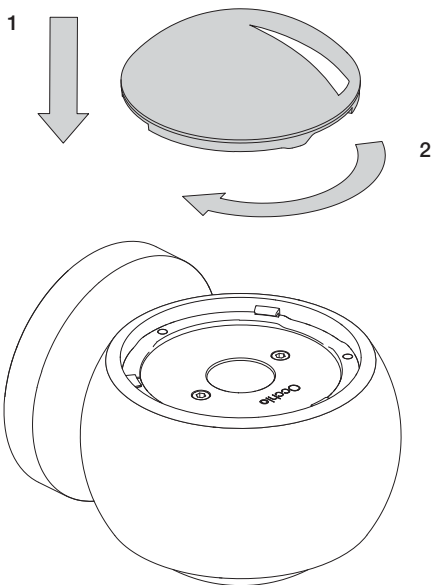

Inserts einsetzen (optional)

Inserting inserts (optional)

1

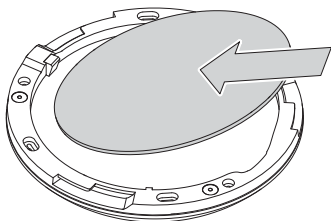

2

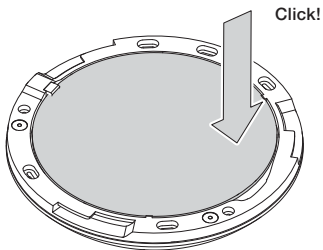

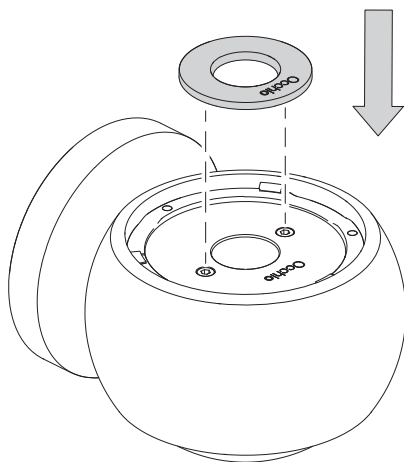

**Blende nur ohne inserts
verwenden.**



**Use aperture just without
inserts.**

Montage
io verticale
VOLT

Mounting
io verticale
VOLT

Montage io verticale VOLT

Mounting io verticale VOLT

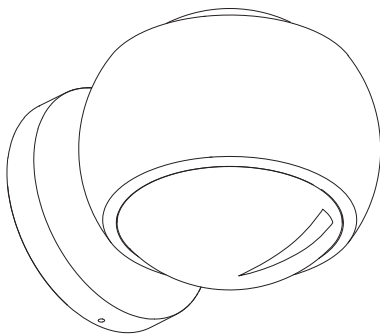



Dübel/
screw anchor



Montageplatte/
mounting plate

Schrauben/
screws



Linse / lens



Blende / aperture

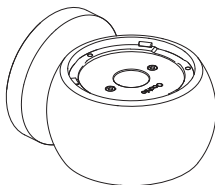

io verticale VOLT



Blende / aperture



Linse / lens



Occhio release-tool

Montage io verticale VOLT

Mounting io verticale VOLT

Netzkabel wie dargestellt anschließen.

Connect the mains cable as shown.

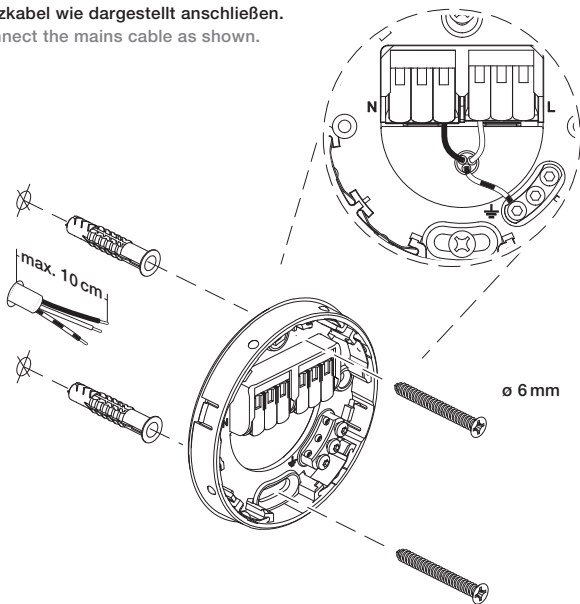

**Vor der Montage alle
stromführenden Leitungen
vom Stromnetz trennen!**



**Before mounting, disconnect
all currentcarrying lines from
the mains supply!**

up / down zusammen steuern
control up / down simultaneously



Kabel der Leuchte wie dargestellt anschließen.

Connect the luminaire's cable as shown.

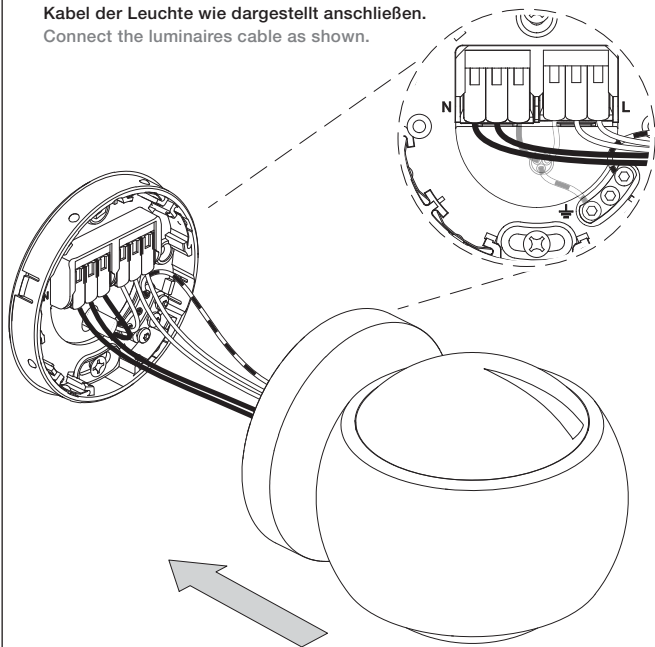

Keine Kabel bei der Befestigung einklemmen!



Do not pinch any cables during mounting!

Montage io verticale VOLT Mounting io verticale VOLT

Um das up / downlight separat steuern zu können sind zwei getrennte Phasen (oder zwei »air« module) notwendig, zusätzlich eine Unterputz- oder Hohlraumdose.

To control up / downlight individually, two separate phases (or two »air« modules) are required, furthermore a flush-mounted or hollow ceiling box.

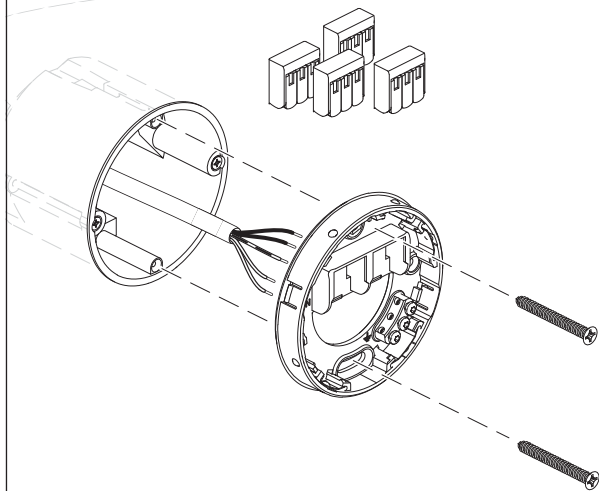

Vor der Montage alle stromführenden Leitungen vom Stromnetz trennen!



Before mounting, disconnect all currentcarrying lines from the mains supply!

up / down getrennt steuern (optional)
control up / down individually (optional)

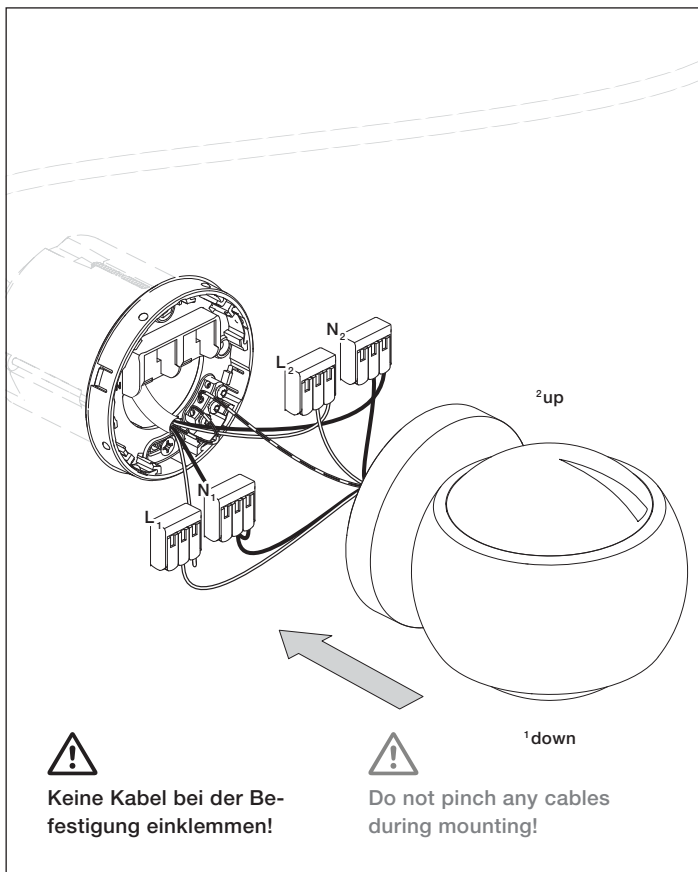

Montage io verticale VOLT Mounting io verticale VOLT

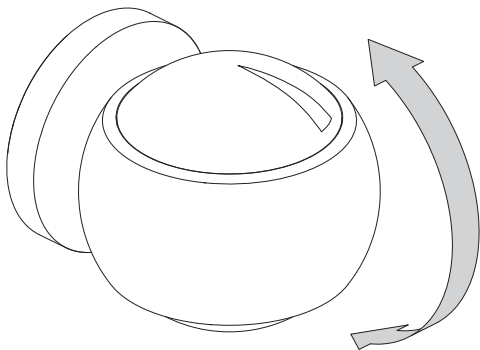

Festen Halt der Leuchte
überprüfen!

**Die Leuchte ist nun fertig
montiert.**

Check that the luminaire is
held in place firmly.

**The luminaire is now fully
mounted.**

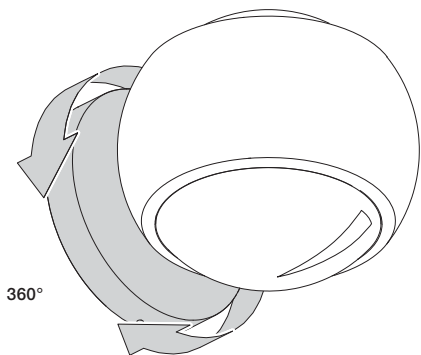

**Zum Ausrichten der Leuchte
am Cover drehen.**



**To adjust the luminaire rotate
the cover.**

Demontage
io verticale
VOLT

Remove
io verticale
VOLT

Demontage io verticale VOLT

Remove io verticale VOLT

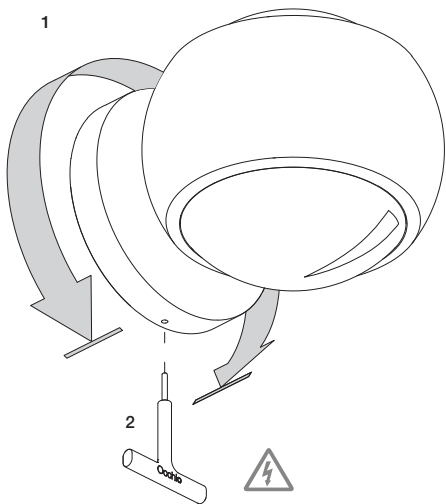

Vor der Demontage alle stromführenden Leitungen vom Stromnetz trennen!

1 Leuchte bis zum Anschlag drehen. **2** Mit dem Release-Tool den Verriegelungsmechanismus nach oben drücken.



Before dismounting, disconnect all current-carrying lines from the mains supply!

1 Turn the luminaire till it stop. **2** Push the locking mechanism by release tool upwards

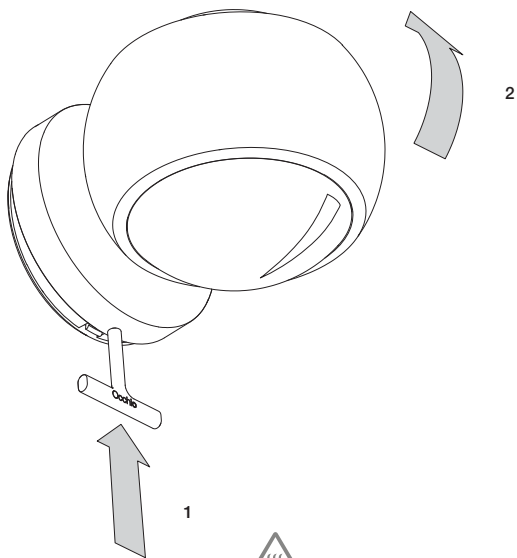

Die Oberfläche der Leuchte kann im Dauerbetrieb heiß werden.

- 1 Tool gedrückt halten.
- 2 Leuchte nach oben neigen.



When used in continuous operation, the surface of the luminaire can become hot.

- 1 Press and hold the tool.
- 2 Tilt the luminaire upwards.

Steuerung mit
der Occhio air
App (optional)

Control using
the Occhio air
app (optional)

Steuerung mit der Occhio air App (optional) Control using the Occhio air app (optional)

Quick guide

Die Occhio air Produkte lassen sich mit der Occhio air App einrichten und steuern.

App installieren, App öffnen und angeschlossene Leuchten einrichten.

Occhio air products can be set up and controlled using the Occhio air app.

Install App, open App and set up connected luminaires.



Occhio air tutorials

www.occhio.com/air-tutorials

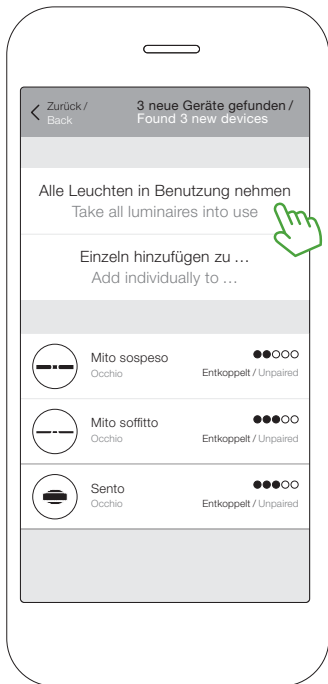

Ein Netzwerk (mein Netzwerk) wird autom. erstellt.

A network (my network) is autom. created.

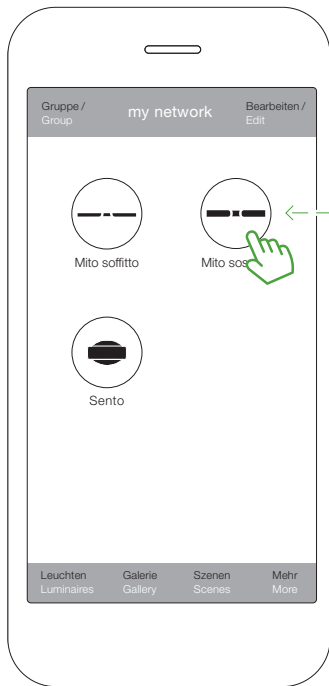

Steuerungsgesten Control gestures

on / off
on / off



antippen
tap

dimmen
dim



wischen
swipe

up / down
faden *



wischen
swipe

color tune **
magic move ***



halten
hold



wischen
swipe

Nur bei Leuchten mit beidseitigem Lichtaustritt *,
color tune ** oder magic move ***

Only for luminaires with double-sided light output *,
color tune ** or magic move ***

Und so werden die Leuchten gesteuert.
And so the luminaires are controlled.

Steuerung mit der Occhio air App (optional) Control using the Occhio air app (optional)

Nutzung auf mehreren Geräten

Use on several devices

Optional können Sie nun ihr
erstelltes Netzwerk (mein
Netzwerk) mit Anderen teilen.

Optionally, you can now share
your created network (my
network) with others.

1. Netzwerknamen
vergeben

1. Assign name

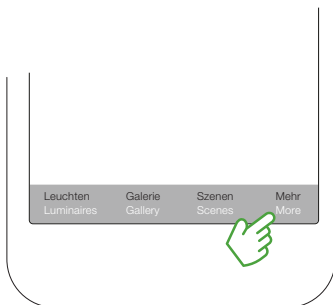

Occhio air tutorials

www.occhio.com/air-tutorials

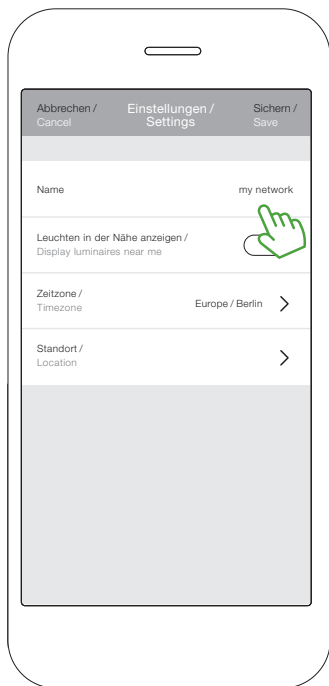

Netzwerkconfiguration → Netzwerkeinstellungen → Namen eingeben → Sichern
Network setup → Network settings → enter name → save

Steuerung mit der Occhio air App (optional) Control using the Occhio air app (optional)

Netzwerk freigeben
und schützen

Share and protect the
network

Occhio air tutorials

www.occhio.com/air-tutorials

2. Netzwerk
freigeben

2. Share network

Leuchten Luminaires	Galerie Gallery	Szenen Scenes	Mehr More
------------------------	--------------------	------------------	--------------



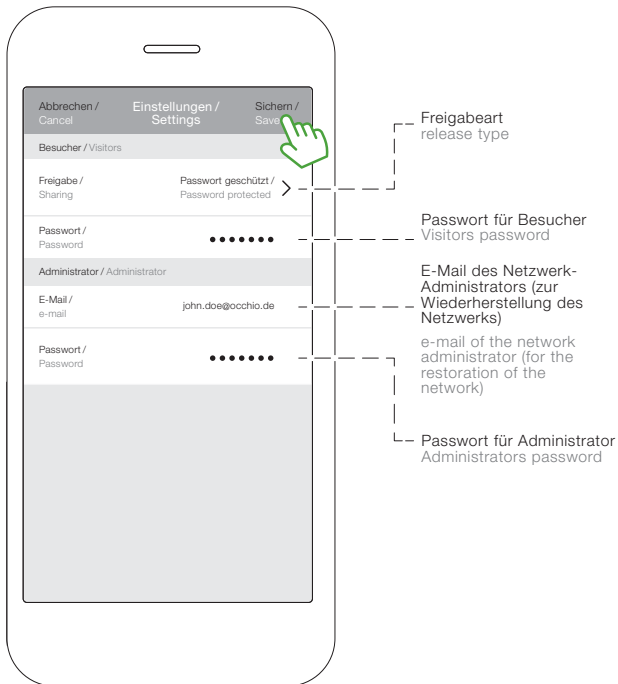

Netzwerkconfiguration → Freigabe-
optionen → Passwort geschützt → Sichern
Network setup → Sharing settings →
Password protected → save

Steuerung mit
dem Occhio air
controller
(optional)

Control using
the Occhio air
controller
(optional)

Steuerung mit dem Occhio air controller (optional) Control using the Occhio air controller (optional)

Occhio air controller

Intuitiv bedienbare Fernbedienung mit vier programmierbaren Tasten (Einrichtung via Occhio air App). Unabhängig von der App können einzelne Leuchten, Gruppen und Szenen gesteuert werden. Optional mit Wandhalterung erhältlich.

Maximaler Bedienkomfort und umfassende Steuerung via Bluetooth 4.0 (Bluetooth Low Energy). Schalten, dimmen, faden, color tune von einzelnen Leuchten, Gruppen und Szenen.

Occhio air controller

Intuitive remote control with four programmable buttons (setup via Occhio air app). Individual luminaires, groups and scenes can be controlled regardless of the app. Available with optional wall mount.

Maximum ease of use and total control via Bluetooth 4.0 (Bluetooth low energy). Switching, dimming, fading, color tune of individual luminaires, groups and scenes.



Zum Einrichten des Occhio air controllers wird die Occhio air App benötigt. Eine Video-Kurzanleitung kann unter: www.occhio.com/air-tutorials aufgerufen werden.

To set up the Occhio air controller, the Occhio air app is required. A video quick start guide can be called up at www.occhio.com/air-tutorials.

schalten/switch



⏏ - ☰ einzelne Leuchten, Gruppen, oder Szenen schalten

⏏ - ☰ switch individual luminaires, groups or scenes

dimmen/dim



⊕ - ☰ einzelne Leuchten, Gruppen, oder Szenen dimmen

⊕ - ☰ dims individual luminaires, groups or scenes

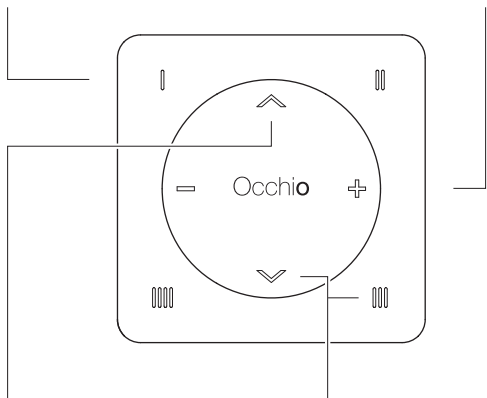

faden*



⤴ ⤵ einzelne Leuchten, Gruppen oder Szenen faden (up/down Verhältnis ändern)

⤴ ⤵ fades individual luminaires, groups or scenes (change up/down relation)

color tune**

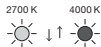

⏏ - ☰ and ⤴ ⤵ Farbtemperatur einzelner Leuchten, Gruppen oder Szenen einstellen

⏏ - ☰ and ⤴ ⤵ adjust color temperature of individual luminaires, groups or scenes

* Leuchten mit beidseitigem Lichtaustritt / luminaires with light emission on both sides ** Mito

Anhang

Appendix

Pflegehinweise

Care instructions

Leuchte nur in abgekühltem Zustand reinigen! Zur Reinigung der Leuchte ein trockenes Mikrofasertuch verwenden. Detaillierte Pflegehinweise sind unter www.occhio.com/de/company/faq zu finden.

Always allow the luminaire to cool down before cleaning! To clean the luminaire, use a dry microfibre cloth. Detailed care instructions are available at www.occhio.com/en/company/faq.

Info & Kontakt

Information & contact





Weitere Fragen beantwortet gerne
Ihr Occhio Fachhändler

Your Occhio specialist retailer will
gladly answer any other questions

www.occhio.com
info@occhio.com

Technische Daten

Technische Daten Leuchte

Artikelbezeichnung	Occhio io verticale VOLT
Abmessungen	L 116 × B 100 × H 94 mm
Schutzklasse	1
Anschluss	230 V AC
Dimmung	via Phasenabschnittdimmer (Liste kompatibler Dimmer: www.occhio.com/dim) oder Occhio air
Material Leuchte	Aluminium, verchromt, lackiert, eloxiert oder PVD-beschichtet, Kunststoff, Glas, optischer Kunststoff
LED-Leistung	18 W (13 W Version chrom glanz, rose gold, bronze)
Zulässige Betriebsbedingung	max. 30°C nur im Innenbereich betreiben
Prüfzeichen	IP 20 CE    

Technische Daten Leuchtmittel





Leuchtmittel	VOLT light engine
Ausführung	LED-Modul (wechselbar)
Lebensdauer	> 40.000 Std.

Entsorgung

Bei örtlicher Entsorgungsstelle entsorgen. Das Leuchtmittel ist recyclebar; RoHS-konform. **Nicht in den Hausmüll geben!**

Technical data

Technical data luminaire

Product designation	Occhio io verticale VOLT
Dimensions	L 116 x W 100 x H 94 mm
Safety class	1
Connection	230 V AC
Dimming	via trailing-edge phasecut dimmer (for a list of compatible dimmers, see www.occhio.com/dim_en) or Occhio air
Luminaire material	aluminium, chrome-plated, painted, anodised or PVC-coated, plastic, glass, optical plastic
LED power	18 W (13 W version shiny chrome, rose gold, bronze)
Permitted operating conditions	max. 30°C for indoor use only
Test symbols	IP 20 CE     

Technical data light source

Light source	VOLT light engine
Version	LED module (replaceable)
Lifetime	> 40.000 h

Disposal

Dispose of at the local waste disposal site. The light source is recyclable and RoHS-compliant. **Do not dispose of with household waste.**

Occhio

www.occhio.com



010040429569668010