

IRIO S

Montage- und Bedienungsanleitung
Mounting and operating instructions

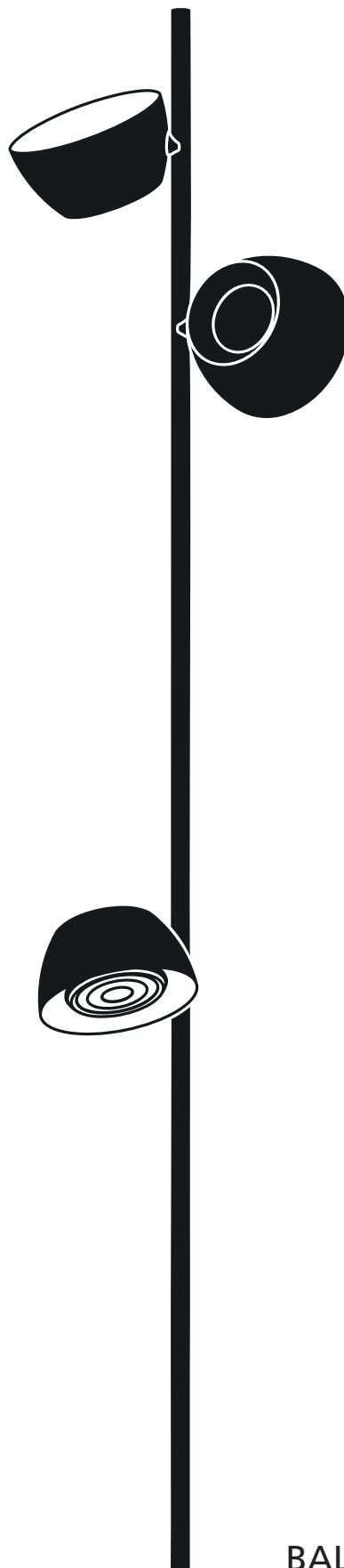

Ⓓ Die Produkte-Abbildungen und Beschreibungen entsprechen dem Stand zum Zeitpunkt der Drucklegung. Technische, formale oder massliche Änderungen sowie Irrtümer sind vorbehalten.

Ⓔ The product images and description correspond to the state at time of printing. Technical, formal or dimensional information are subject to change.

DE

Anleitungen vorgängig sorgfältig lesen und für künftiges Nachlesen aufbewahren. Beachten Sie die Schutzklassen und befolgen Sie die Sicherheitsbestimmungen und Instruktionen auf Seite 3.



Inhalt:

Schutzklassen, Sicherheitsbestimmungen und Instruktionen	3
Montageanleitung	4–5
Bedienungsanleitung	6–7



Lieferumfang:

- Leuchte komplett, vormontiert (Gestänge zweiteilig, verdrahtet)
- 1 x Optik
- 3 x Clip (Reserve)
- 1 x Schraube – für allfällige Verwendung, siehe Punkt ① auf Seite 7.

EN

Read the instructions carefully beforehand and keep them for future reference. Observe the protection classes and follow the safety regulations and instructions on page 9.



Content:

Protection classes, safety regulations and instructions	9
Mounting instructions	10–11
Operating instructions	12–13



Scope of delivery:

- Complete luminaire, pre-assembled (two-part rod, pre-wired)
- 1 x Optic
- 3 x Clip (reserve)
- 1 x screw – for possible use, see item ① on page 7.

 Leuchte darf ausschliesslich bei einer Netzspannung von 220-240 V 50/60 Hz eingesetzt werden. Bei der Montage sind die gesetzlichen Installations- und Unfallverhütungsvorschriften zu beachten. Bei Montage, Reinigungs- und Wartungsarbeiten immer die Stromzufuhr unterbrechen. Reparaturen dürfen nur vom Hersteller oder durch eine qualifizierte Fachkraft gemäss der geltenden Normgebung ausgeführt werden. Bei unsachgemässer Installation oder Manipulation an der Leuchte entfallen alle Gewährleistungsansprüche sowie die Produkthaftungspflicht des Herstellers nach der europäischen Richtlinie über die Haftung für fehlerhafte Produkte (85/374/EWG) und dem schweizerischen Bundesgesetz über die Produkthaftung (PrHG). BALTENSWEILER übernimmt keine Haftung für Sach- und Personenschäden, die durch unsachgemässe Handhabung oder Nichtbeachten der Sicherheitsbestimmungen entstehen!

Die Leuchte erwärmt sich im Betrieb. Die Leuchte darf nicht mit produktfremden Gegenständen belastet und bestückt werden (Bruch- / Sturzgefahr), sowie auch während des Betriebs nicht mit Gegenständen (z.B. Textilien) überdeckt werden (Brandgefahr). Halten Sie Optik, Schutzglas und Leuchtmittel frei von Verunreinigungen (Pfleheinweis beachten). Solche Verunreinigungen können zu einer erhöhten Wärmeentwicklung führen, welche die Leuchte zerstören kann.

LEDs sind fest verbaut und dürfen nur durch den Hersteller gewechselt werden.

 In der Leuchte sind kleine magnetische Komponenten verbaut. Magnete können die Funktion von Herzschrittmachern / implantierten Defibrillatoren beeinflussen.

Empfohlener Sicherheitsabstand vom Magneten:

85 mm bei neuen Versionen mit max. erlaubtem Magnetfeld von 1 mT = 10 G.



























































































































































































105 mm bei älteren Versionen mit max. erlaubtem Magnetfeld von 0.5 mT = 5 G.

Weitere Informationen unter: www.baltensweiler.ch/service/faq/

 LEDs nicht unmittelbar ins Auge richten!

 Elektronische Bauteile sind empfindlich gegen elektrostatische Entladung und können bereits beim Berühren der Anschlüsse zerstört werden. Für die Montage sind geeignete ESD-Schutzmassnahmen (Electro Static Discharge) zu treffen.

 Externe Dimmer, inkl. Wanddimmer sind nicht zulässig und können die LED bzw. das Betriebsgerät zerstören!

Die Leuchte darf erst an die Stromversorgung angeschlossen werden, wenn sie vollständig montiert und platziert ist.

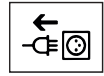

Wichtig: Das Gestänge wird zweiteilig und bereits vorverdrahtet angeliefert. Die Montage der Leuchte kann werkzeuglos durchgeführt werden.

① Leuchte schrittweise auspacken und montieren:

- ①.1 Leuchte mit Schutzkarton am Griff aus der Transportschachtel ziehen.

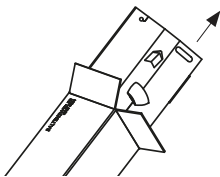

- ①.2 Die Optik im Beutel entnehmen.



- ①.3 Oberen Kartonwinkel herausziehen.

- ①.4 Seitliche Laschen lösen.

- ①.5 Kartonlasche nach unten klappen (Winkel noch **nicht** entfernen).

- ①.6 Schutzkarton öffnen.

- ①.7 Kartonlaschen von oberem Gestänge (mit Leuchtenköpfe) lösen.

- ①.8 Oberes Gestänge mit Leuchtenköpfe auf Verbinder aufsetzen (Arretierungsstift wenn nötig leicht hineindrücken).

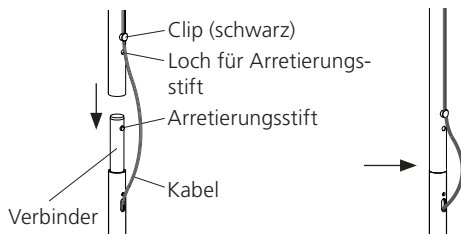

- ①.9 Kartonlaschen von unterem Gestänge lösen.

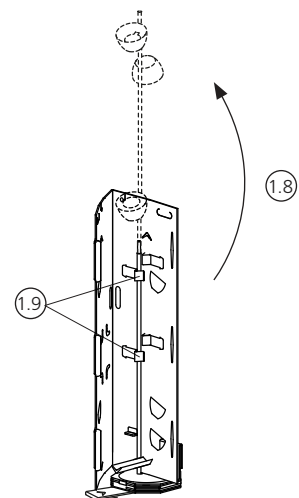
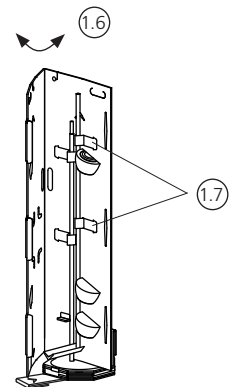
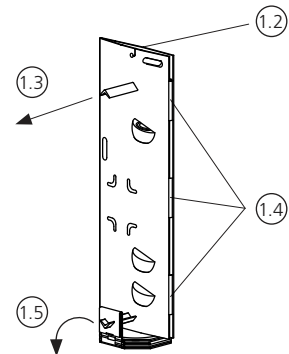

DE Montageanleitung

② Gesamte Verpackung vorsichtig entfernen.

③ Die Leuchtenköpfe nach Wunsch platzieren (Magnethalterung).

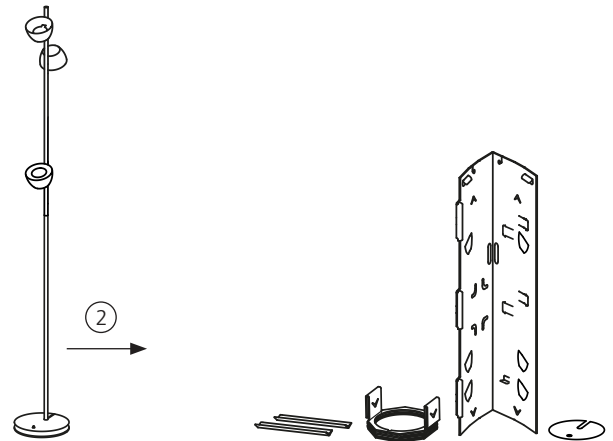

④ Die Kabel bei den Köpfen jeweils nachziehen und an der Stange bei den Clips bzw. Magneten ausrichten und gerade ziehen. Jeweils bei den Köpfen so viel Kabel frei lassen, dass diese gut gedreht werden können.

⑤ Optik im unteren Leuchtenkopf (Arbeits- und Leselicht) befestigen (Optik wird magnetisch gehalten).



IRIO OPTIK Abstrahlwinkel 40°:
1 Stück im Lieferumfang bei Leuchten
bestückt mit LEDs 2700 K oder DTW.
Art. 6700-65

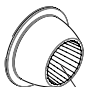

IRIO OPTIK Abstrahlwinkel 60°:
Art. 6700-66
(Nicht im Lieferumfang enthalten – muss
separat bestellt werden)

Wichtig: Innenfläche des Reflektors nicht berühren!

⑥ Überschüssiges Kabel durch die Gestängeöffnung in das untere Gestänge zurückschieben.

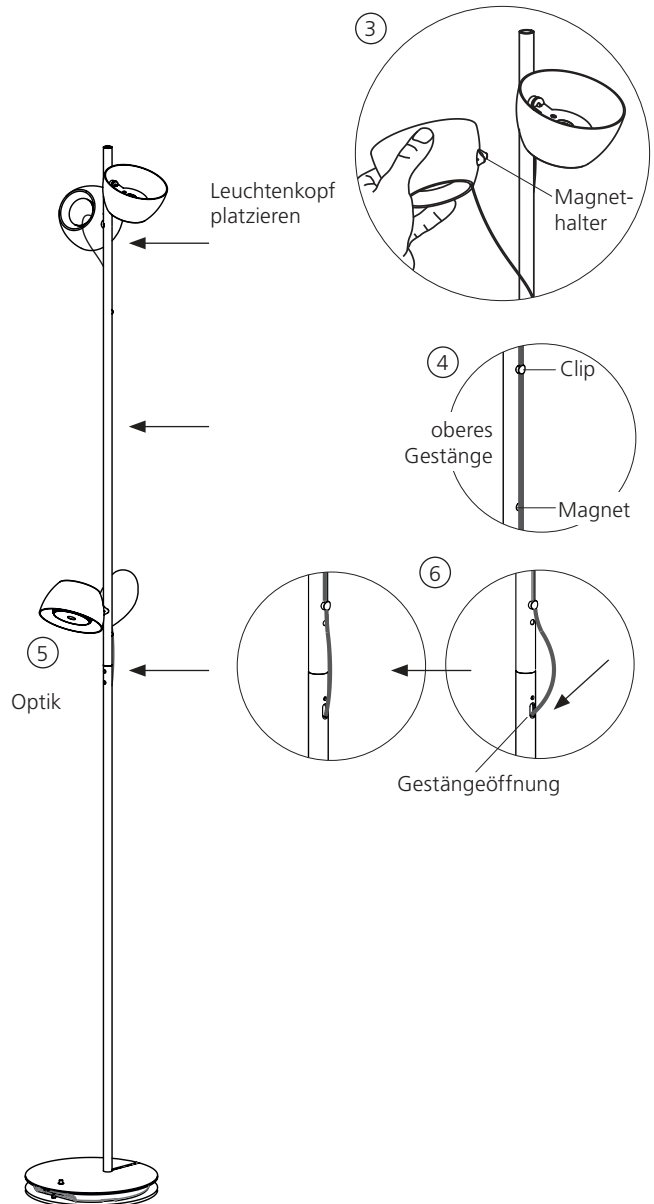

Ist die Leuchte vollständig montiert und platziert, darf sie an die Stromversorgung angeschlossen werden.

DE Bedienungsanleitung

(A) Leuchtenkopf schwenkbar.

(B) Leuchtenkopf drehbar um Gestänge.

(C) Leuchtenkopf werkzeuglos höhenverstellbar
(hält magnetisch).

Für den Fall, dass sich beim Umsetzen des Leuchtenkopfes der Kopfhalter löst, finden Sie unter (I) auf Seite 7 die Anleitung, wie dieser ohne grossen Aufwand wieder eingesetzt werden kann.

(D) Tasten Raumlicht / Leselicht:
Tastendruck kurz: Ein- / Ausschalten
Tastendruck lang: Dimmen (abwechslungsweise stufenlos von 100% zu 2% oder 2% zu 100%).

(E) Leselicht – Leuchtenkopf mit Optik für eine optimale Lichtführung und Entblendung des direkten Lichtes. Die Optik wird magnetisch gehalten und kann auch werkzeuglos demontiert bzw. getauscht werden.

(F) Hauptschalter zum Ausschalten der Leuchte
(kein Standby-Verbrauch).

(G) Sockel mit Kabeldepot und Kabelarretierungsstift.

(H) Der Leuchtenkopf wird in Betrieb im Bereich der LED heiss. Die LED darf weder berührt noch direkt gereinigt werden (mechanische / chemische / elektrostatische Beschädigung der LED).

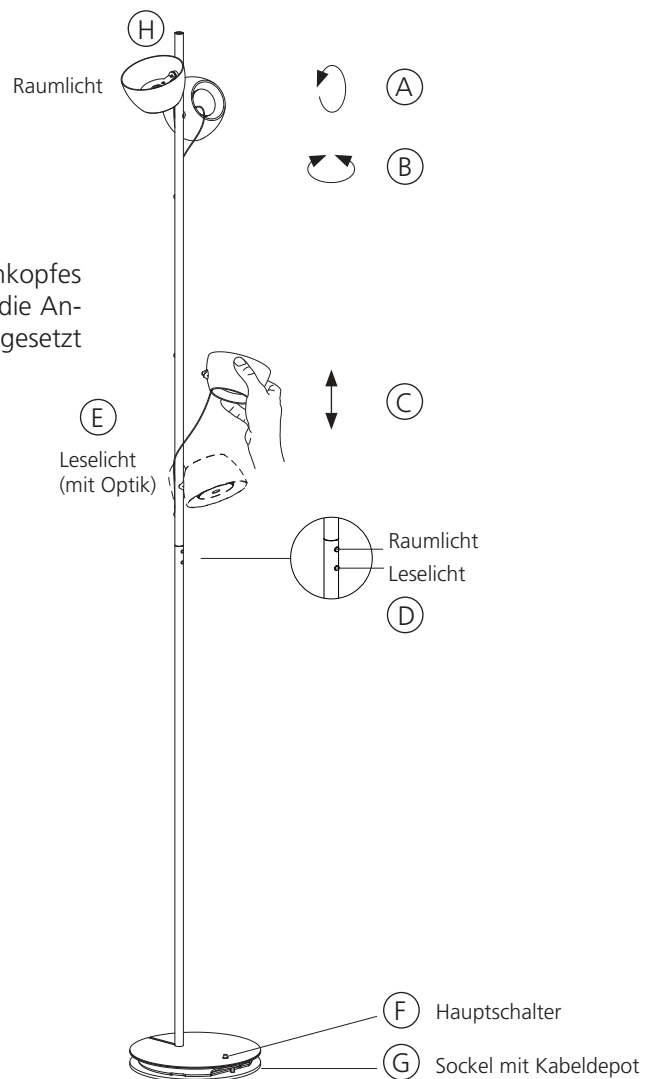

- ① Kopfhalter in Leuchtenkopf neu einsetzen (hält magnetisch):
Um den Magnet wieder in dem Kopfhalter platzieren zu können, kann die mitgelieferte Schraube (M4 x 35) zur Hilfe genommen werden. Alternativ zur Schraube kann ein länglicher Gegenstand Länge ca. 30 mm mit einem Durchmesser von 5 – 10 mm verwendet werden.



- ① Den Magnet auf den Schraubenkopf setzen.
② Danach den Kopfhalter von unten nach oben über die Schraube einfahren.
Dabei sollte der Magnet sich selbst im Halter einmitten.
③ Anschliessend die Schraube vom Kopfhalter (inkl. Magnet) entfernen.

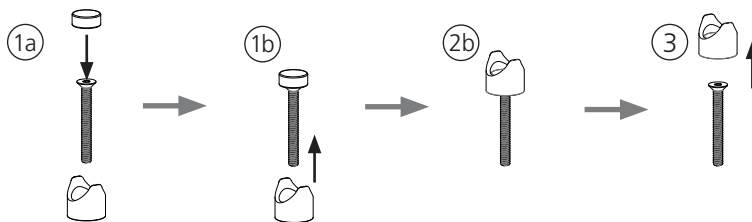

- ④ Nun den Kopfhalter (inkl. Magnet) in die Aussparung im Leuchtenkopf einfahren (hält magnetisch am Leuchtenkopf).

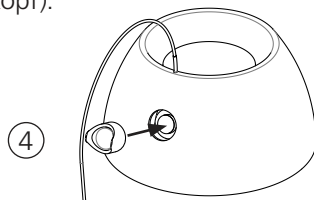

- ⑤ Der komplette Leuchtenkopf kann jetzt an der Stange platziert werden (hält magnetisch).

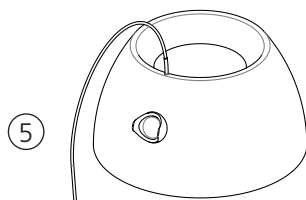

-  The luminaire may only be used with a mains voltage of 220-240 V 50/60 Hz. For mounting, observe the statutory installation and safety regulations. Always disconnect the power supply when carrying out installation, cleaning or maintenance tasks. Repairs may only be carried out by the manufacturer or by a qualified specialist in accordance with the applicable standards. In the event of incorrect installation or that the luminaire has been tampered with, all warranty claims shall be rendered invalid, as will the manufacturer's product liability obligation in accordance with the European Directive concerning Liability for Defective Products (85/374/EEC) and the Swiss Federal Law on Product Liability (PrHG). BALTENSWEILER shall assume no liability for any loss or damage to persons or property caused by improper handling or non-adherence to the safety regulations!

The luminaire heats up during operation. The luminaire must not be loaded and equipped with objects that are not part of the product (risk of breakage / falling), and must not be covered with objects (e.g. textiles) during operation (fire hazard). Keep the optic, protective glass and lamp free of dirt (follow the care instructions). Such impurities can lead to increased heat generation which can destroy the luminaire.

LEDs are permanently installed and may only be replaced by the manufacturer.

-  Small magnetic components are installed in the luminaire. Magnets may affect the function of pacemakers or implanted defibrillators.
Recommended safety distance from the magnet:
85 mm for new versions with a max. permitted magnetic field of 1 mT = 10 G.
105 mm for old versions with a max. permitted magnetic field of 0.5 mT = 5 G.
You will find further information on: www.baltensweiler.ch/service/faq/

-  Do not shine the LEDs directly into eyes!

-  Electronic components are sensitive to electrostatic discharge and can be destroyed if the connections are touched. Suitable protective measures against ESD (Electro Static Discharge) must be taken.

-  External dimmers (including wall-mounted dimmers) are NOT permitted and can damage the LEDs and the control gear.

-  Care instructions: Disconnect the power supply. Wipe with a damp cloth. Do not use abrasive, alcoholic or electrostatically charged cleaning utensils. Do not touch the protective glass above the LED (mechanical / chemical / electrostatic damage to the LEDs)!

-  The luminaire may only be installed in dry interior spaces.

-  Correct disposal / Luminaire must not be disposed of with the normal household waste.

-  Protection class II:
Equipment with protection class II has reinforced or double insulation between the active and accessible parts equal to the rated insulation voltage.

- IP20** Protection class IP20:
Protection against contact with fingers and medium-sized solid foreign bodies $\varnothing \geq 12$ mm.

- CE** Technical conformity in accordance with EN directives.

The luminaire must not be connected to the power supply until it is fully mounted and placed.

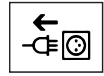

Important: The rod is delivered in two parts and is already pre-wired. The luminaire can be installed without tools.

① Unpack and assemble the luminaire step by step:

- ①.1 Remove the luminaire and protective box from the shipping carton by the handle.

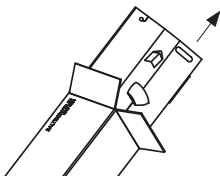

- ①.2 Remove the optics in the bag.

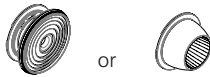

- ①.3 Pull out the upper cardboard bracket.

- ①.4 Loosen the tabs on the side.

- ①.5 Fold down the flap, do **NOT** remove the lower cardboard bracket yet.

- ①.6 Open the protective cardboard box.

- ①.7 Loosen the tabs holding the upper part of the rod.

- ①.8 Place the rod with the lampheads directly on the connector in the lower rod (press the locking pin in slightly, if necessary).

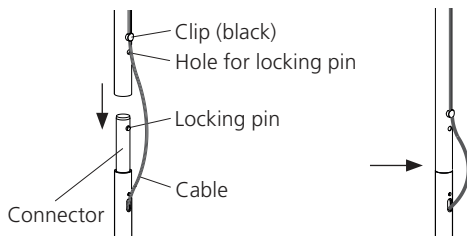

- ①.9 Loosen the 2 tabs holding the under part of the rod.

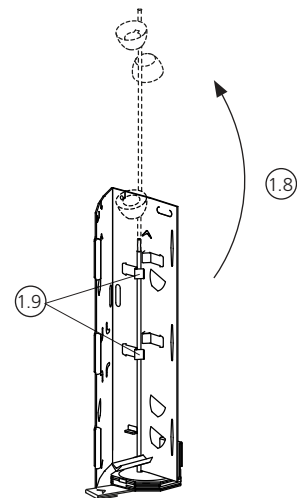
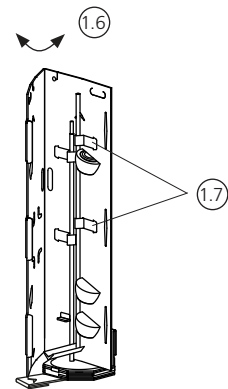
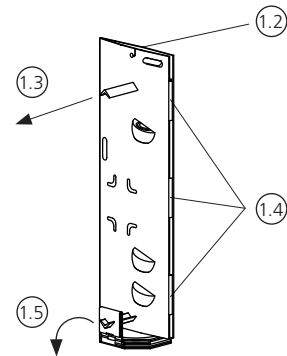

EN Mounting instructions

② Carefully remove the complete packaging.

③ Position the lamp heads as required (magnetic holder).

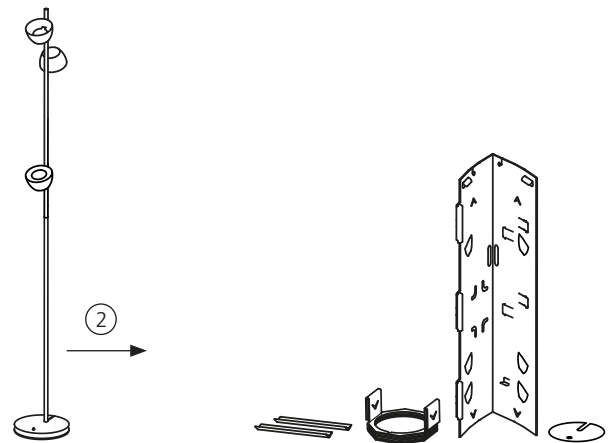

④ Tighten each of the cables on the heads, align with the clips or magnetic holders on the rod and pull straight. Leave enough cable free on each head so that this can be rotated freely.

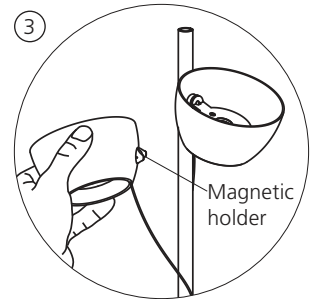

⑤ Fasten the optic in the lower lamp head (reading light). (Held in place by magnets).



IRIO OPTIC beam angle 40°:
1 piece included with luminaires equipped with LEDs 2700 K or DTW.
Art. 6700-65



IRIO OPTIC beam angle 60°:
Art. 6700-66
(Not included in the scope of delivery – must be ordered separately)

Important: Do not touch the inner surface of the reflector!

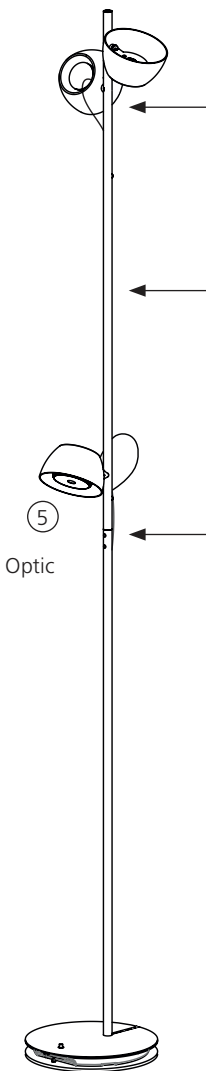
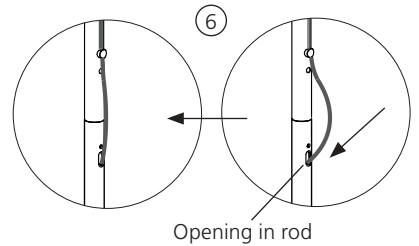
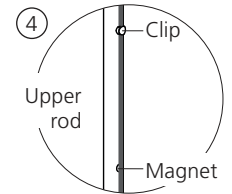

⑥ Push excess cable back into the lower rod through the opening.

Once the luminaire is fully mounted and placed, it may be connected to the power supply.

EN Operating instructions

(A) Swivelling lamp head.

(B) Lamp head rotatable about rod.

(C) Luminaire head height adjustable without tools (holds magnetically).

In the event that the head holder comes loose when the luminaire head is moved, you will find instructions (I) on page 13 on how to reinsert it without great effort.

(D) Room / reading light buttons:
Short press on button: Switch on/off
Long press on button: Dim (alternately stepless from 100% to 2% or 2% to 100%)

(E) Reading light – lamp head with optic for optimum light guidance and glare-free direct light.
The optic is held in place magnetically and can also be dismantled or replaced without tools.

(F) Main switch for switching the luminaire off (no standby consumption).

(G) Base with cable store and cable locking pin.

(H) The luminaire head becomes hot in the area of the LED during operation. The LED must not be touched or cleaned directly (mechanical / chemical / electrostatic damage to the LED).

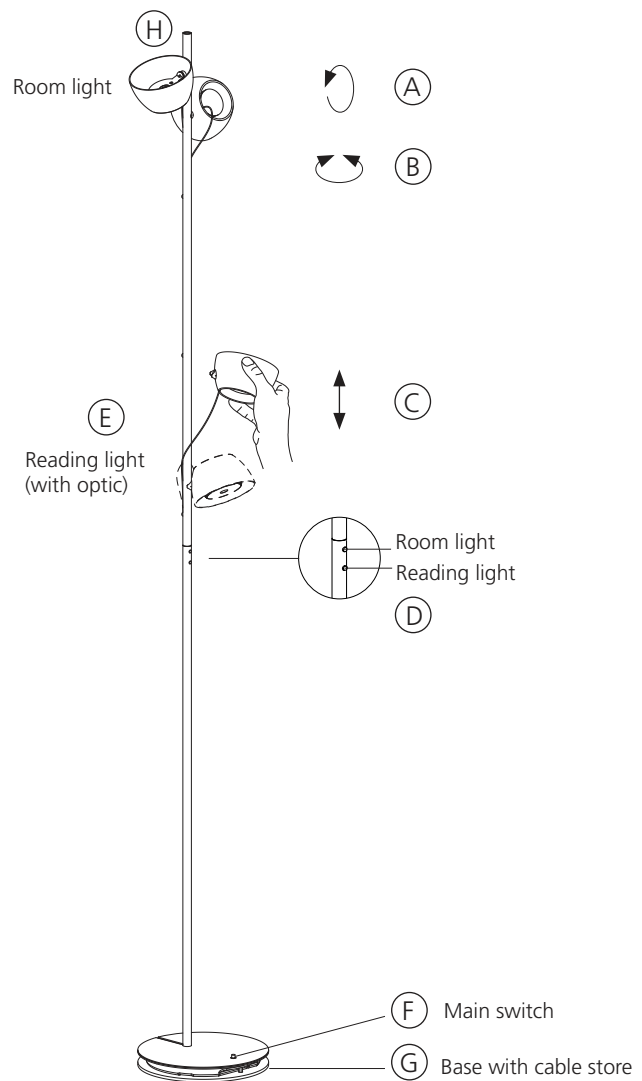

- ① Replace the head holder in the lamp head (holds magnetically):
 The supplied screw (M4 x 35) can be used to place the magnet back in the head holder. As an alternative to the screw, an elongated object with a length of approx. 30 mm and a diameter of 5 – 10 mm can be used.

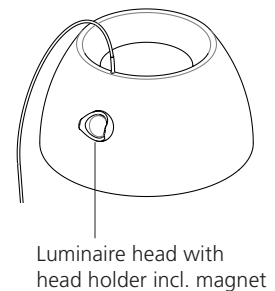

- ① Place the magnet on the screw head.
- ② Then retract the head holder over the screw from bottom to top. The magnet should centre itself in the holder.
- ③ Then remove the screw from the head holder (including magnet).

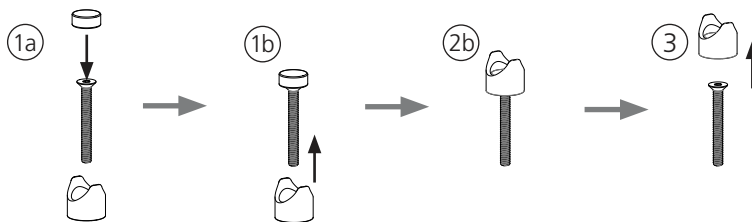

- ④ Now insert the head holder (incl. magnet) into the recess in the lamp head (holds magnetically on the lamp head).

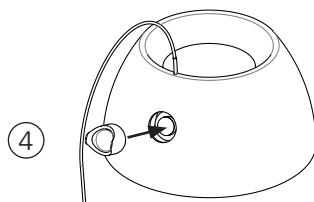

- ⑤ The complete luminaire head can now be placed on the rod (holds magnetically).

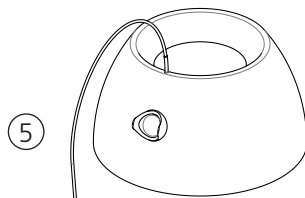

BALTENSWEILER AG
Staldenhof 2
6014 Luzern

T +41 41 429 00 30
info@baltensweiler.ch

