

Occhio

Sento head beidseitig

Sento head double-sided

Montage- / Bedienungsanleitung

Mounting instructions / user manual

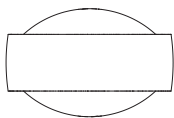

Inhalt / Contents

Sicherheitshinweise	04	Safety precautions	05
Produktbeschreibung	06	Product description	07
Schritt 1		Step 1	
head ohne »air«	09	head without »air«	09
OFF	11	OFF	11
DIM	15	DIM	15
STEP	19	STEP	19
head mit »air«	23	head with »air«	23
OFF + »air«	25	OFF + »air«	25
DIM + »air«	29	DIM + »air«	29
STEP ohne »air«	33	STEP without »air«	33
Schritt 2		Step 2	
Montage	39	Mounting	39
inserts	40	inserts	40
head + body /	48	head + body	48
head abnehmen /	50	remove head	50
Wechsel Karbongriff / Fixiererring	52	Changing carbon rod / fixing ring	52
Anhang	55	Appendix	55
Pflegehinweise	56	Care instructions	56
Info & Kontakt	57	Information & contact	57
Technische Daten	58	Technical data	59

Sicherheitshinweise

Lesen Sie die Montage-/Gebrauchsanweisung sorgfältig durch, bevor Sie die Leuchte installieren. Beachten Sie die Sicherheitshinweise in dieser Anleitung genau und bewahren Sie die Anleitung auf.



Dieses Zeichen macht Sie auf eine gefährliche Situation aufmerksam, die eine schwere Verletzung oder den Tod nach sich ziehen kann, wenn sie nicht beachtet wird. Es macht Sie zudem auf mögliche Sachschäden und andere wichtige Informationen in Verbindung mit diesem Produkt aufmerksam.



Die Montage von Elektrokomponenten darf nur von qualifiziertem Fachpersonal durchgeführt werden. Reparaturarbeiten dürfen nur von autorisiertem Fachpersonal oder dem Hersteller durchgeführt werden. Vor allen Arbeiten an der Leuchte (Installation, Reinigung etc.) diese unbedingt vom Stromnetz trennen.



Dieses Zeichen macht Sie auf Situationen aufmerksam, bei denen Sie direkt in das Licht der LED blicken könnten. Dies kann zu Nachbildern und bei längerer Dauer zu Schädigungen der Augen führen.



Sicherheitsabstand zu brennbaren Objekten einhalten: 20 cm!



Dieses Zeichen macht Sie auf heiße Oberflächen aufmerksam, deren Berührung Verbrennungen zur Folge haben können.

Achtung: Die Oberfläche der Leuchte kann nach längerer Betriebsdauer heiß sein! Vor allen Arbeiten an der Leuchte (Montage usw.), Leuchte immer ausschalten und mindestens 30 Minuten abkühlen lassen.

Safety precautions

Read through the mounting/ use instructions carefully before installing the luminaire. Follow the safety precautions in these instructions closely and keep the instructions in a safe place.



This symbol warns you of a dangerous situation which could lead to serious injury or even death if the instructions are not observed. It also draws your attention to possible material damage and provides other important information in connection with this product.



The assembly and installation of electrical components must be carried out only by qualified personnel. Repairs must be carried out only by authorised, qualified personnel or the manufacturer. Before performing any work on the luminaire (installation, cleaning, etc.), it must be disconnected from the mains supply.



This symbol draws your attention to situations in which you could look directly into the light of the LED. This may cause an after-image effect and may result in damage to the eyes if you look at the light directly for prolonged periods.



Maintain the minimum safety distance from flammable materials: 20 cm.



This symbol warns you of hot surfaces, which could cause burns if touched.

Caution: When used for prolonged periods, the surface of the luminaire can become hot. Before performing any work on the luminaire (fitting the luminaire etc.), always switch the luminaire off and let it cool for at least 30 minutes.

Produktbeschreibung

Lichtleistung 18 W oder 26 W
(einstellbar).

Lichtwirkung über optionale inserts
veränderbar, dichroitische Farbfil-
ter zusätzlich einsetzbar. Verstell-
möglichkeit über wärmeentkop-
pelten Karbongriff (head optional
gegen Verdrehen fixierbar).

Extern dimmbar via Phasenab-
schnittdimmer (abhängig vom
Vorschaltgerät) oder über Gesten-
steuerung »touchless control« am
head.

Optional mit Occhio air erhältlich,
Steuerung zusätzlich via Occhio air
App oder Occhio air Controller. Bei
Leuchten mit mehreren heads ist
nur ein »air« head notwendig.

Phasenabschnittdimmer und Occhio air nicht kombinierbar

Product description

Light output, power of light source
18 W or 26 W (adjustable).

Lighting effect changeable by using optional inserts, dichroic color filters can be added. Adjustment via heat-decoupled carbon pin (fixation of head against rotation optional).

Controllable via trailing-edge phasecut dimmer (depending on the power supply unit) or via »touchless control« with gestures at the head.

Optionally available with Occhio air, additional control via Occhio air app or Occhio air controller. For luminaires with multiple heads, only one »air« head is necessary.

trailing-edge phasecut dimmer and Occhio air not combinable



Oberseite / this side up

26 W nicht für den Handbereich empfohlen (Wärmeentwicklung)*
26 W not recommended for the hand area (heat buildup)*

18 W für den Handbereich empfohlen

18 W recommended for the hand area

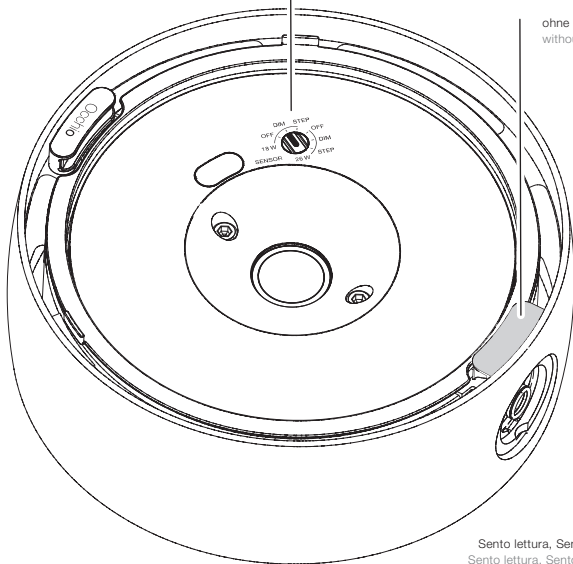

ohne Occhio air
without Occhio air

Sento lettura, Sento tavolo nur mit 18 W*
Sento lettura, Sento tavolo with only 18 W*

head ohne

» air «

Funktionen / Steuerungs-
möglichkeiten

head without

» air «

Functions / control options

OFF

extern schalten und dimmen (Sensor aus)
switch and dim externally (sensor off)

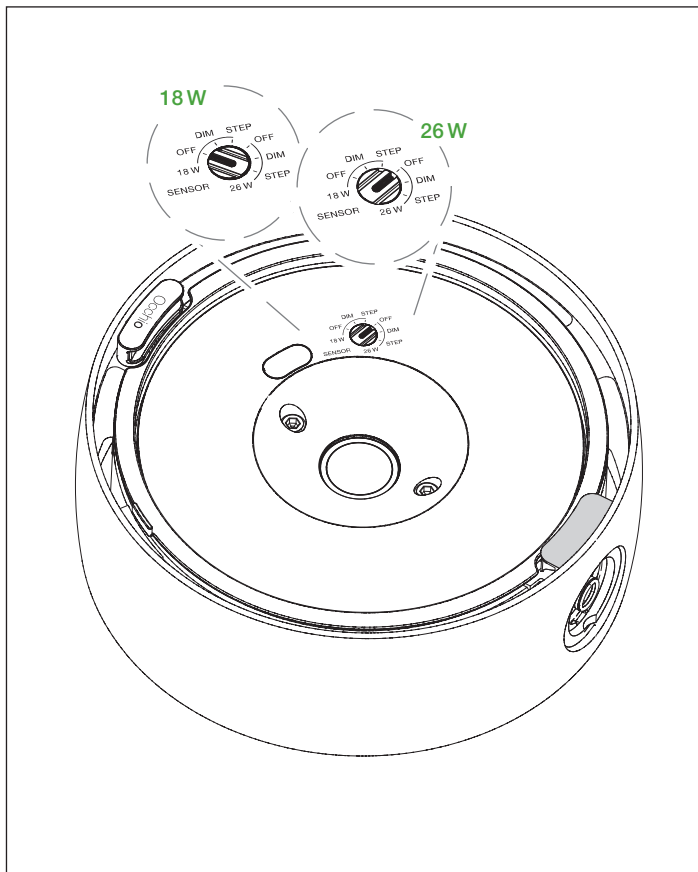

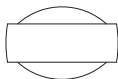

Schalter / Dimmer*
switch / dimmer*



extern Schalten und Dimmen (kein »touchless control«) /
switching and dimming external (no »touchless control«)

* nicht mögl. bei Sento tavolo, Sento terra, Sento lettura; dimmen nur mit Occhio Konverter
(Liste kompatibler Dimmer: www.occhio.com/dim, Phasenabschnittdimmer)
* not possible with Sento tavolo, Sento terra, Sento lettura; dimming only with Occhio converter
(for a list of compatible dimmers, see www.occhio.com/dim_en, trailing-edge phasecut dimmer)

DIM

» touchless control «

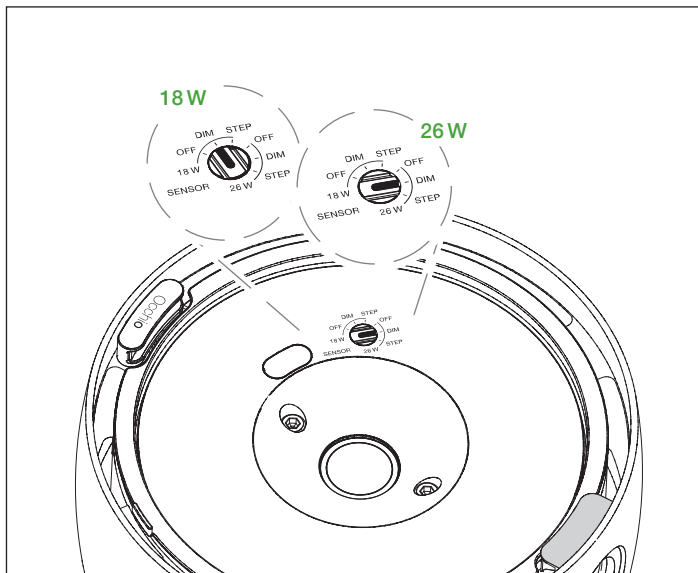

Sensorzone / sensor zone 8 cm

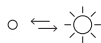
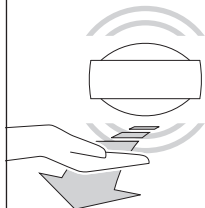

on / off
bewegen / move your hand

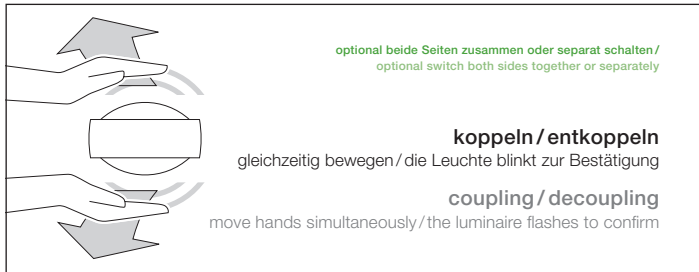
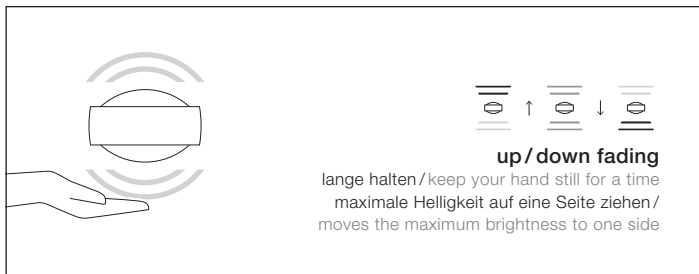

STEP

up- / down preset (Sensor aus) / (sensor off)

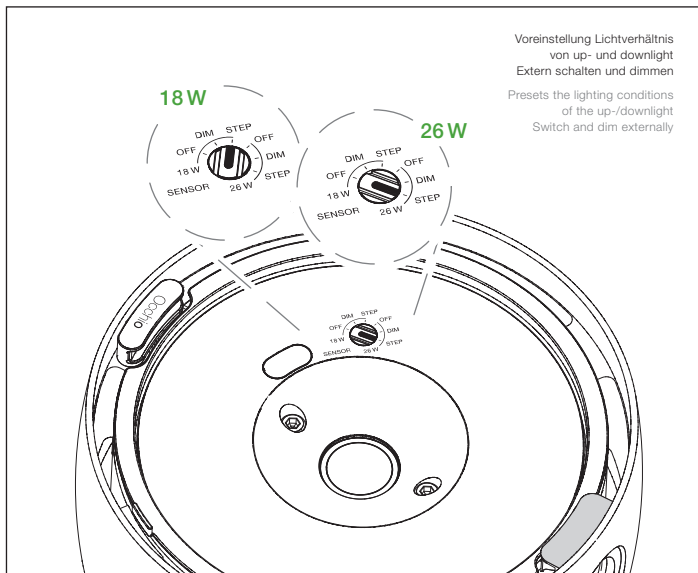

Sensorzone / sensor zone 8 cm

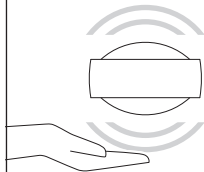

10 Sek. halten / hold for 10 seconds
Leuchte wird entsperrt und blinkt zur Bestätigung /
Luminaire is unlocked and flashes to confirm

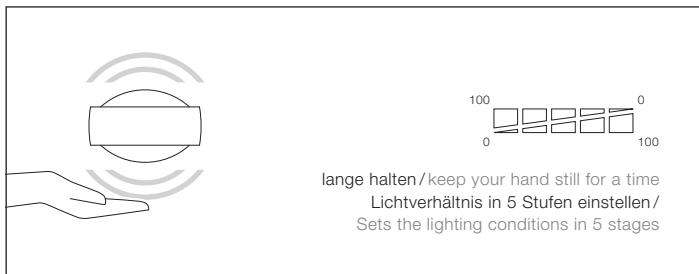

lange halten / keep your hand still for a time
Lichtverhältnis in 5 Stufen einstellen /
Sets the lighting conditions in 5 stages

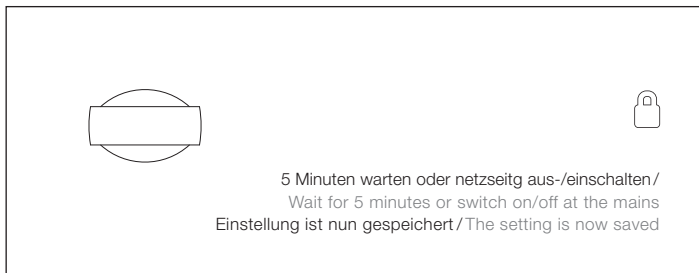

5 Minuten warten oder netzseitig aus-/einschalten /
Wait for 5 minutes or switch on/off at the mains
Einstellung ist nun gespeichert / The setting is now saved



Schalter / Dimmer*
switch / dimmer*

Schalten und Dimmen (kein »touchless control«) /
switching and dimming (no »touchless control«)
Leuchte bleibt in der gespeicherten Einstellung /
The saved setting for the luminaire remains unchanged

* dimmen nur mit Occhio Konverter (Liste kompatibler Dimmer: www.occhio.com/dim, Phasenabschnittdimmer)
* dimming only with Occhio converter (for a list of compatible dimmers, see www.occhio.com/dim_en, trailing-edge phasecut dimmer)



Oberseite / this side up

26 W nicht für den Handbereich empfohlen (Wärmeentwicklung)*
26 W not recommended for the hand area (heat buildup)*

18 W für den Handbereich empfohlen
18 W recommended for the hand area

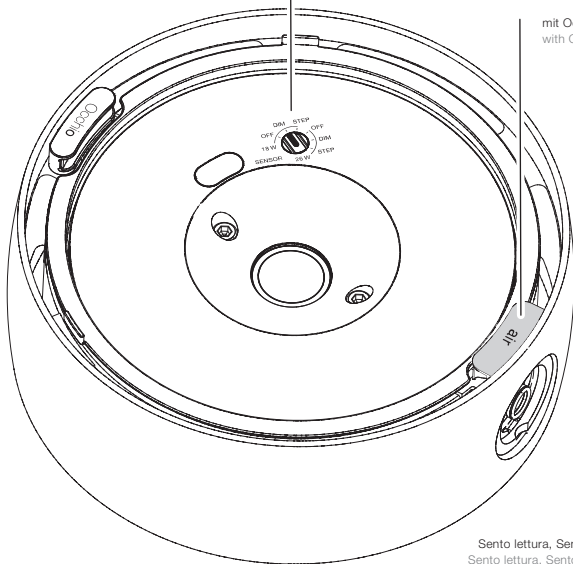

mit Occhio air
with Occhio air

Sento lettura, Sento tavolo nur mit 18 W*
Sento lettura, Sento tavolo with only 18 W*

head mit

» air «

Funktionen / Steuerungs-
möglichkeiten

head with

» air «

Functions / control options

OFF + » air «

»air« (Sensor aus) / (sensor off)

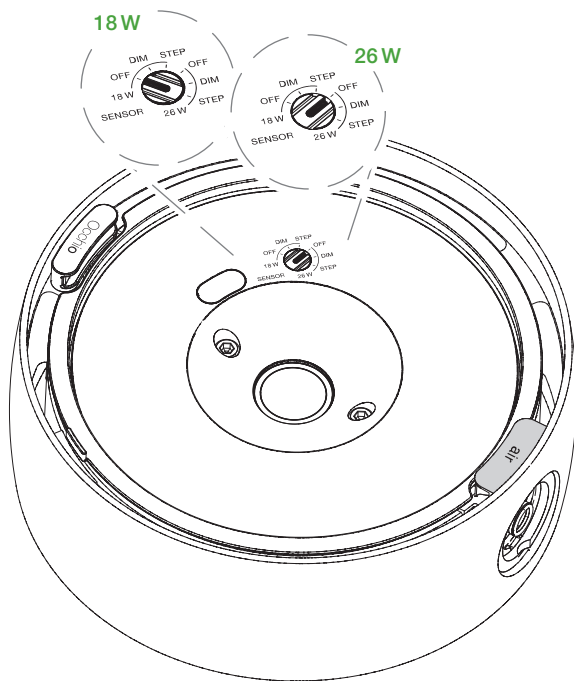

* Phasenabschrittdimmer und Occhio air nicht kombinierbar /
trailing-edge phasecut dimmer and Occhio air not combinable

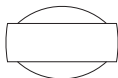

Occhio air siehe separates Handbuch.

Occhio air see seperate manual.

* dimmen nur mit Occhio Konverter (Liste kompatibler Dimmer: www.occhio.com/dim, Phasenabschnittdimmer)

* dimming only with Occhio converter (for a list of compatible dimmers, see www.occhio.com/dim_en, trailing-edge phasecut dimmer)

DIM + » air «

» touchless control « + » air «

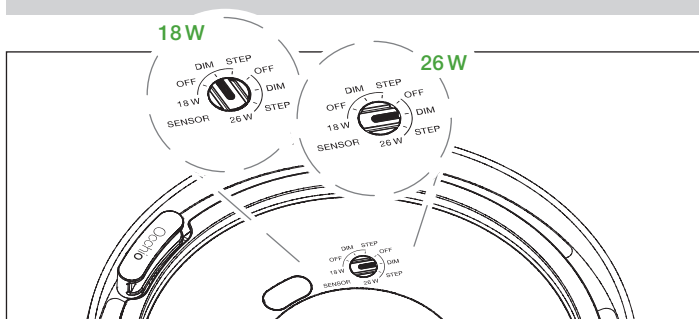

Sensorzone / sensor zone 8 cm

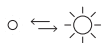
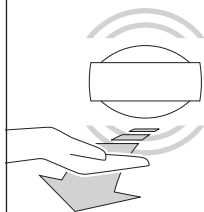

on / off

bewegen / move your hand

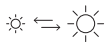
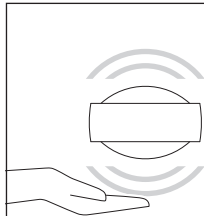

dimmen / dim

halten / keep your hand still

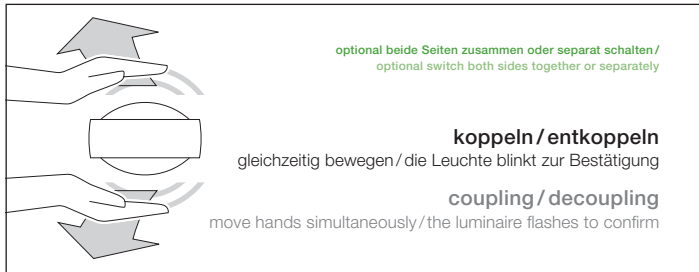
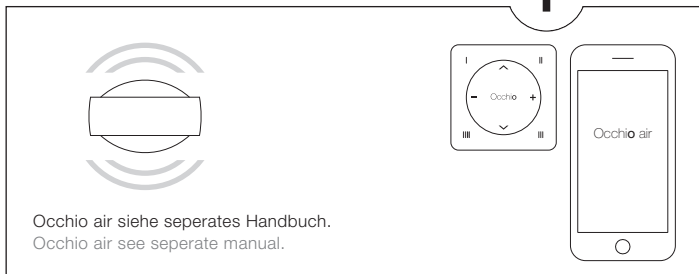
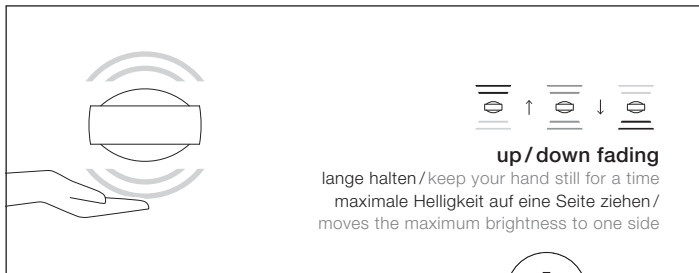

STEP ohne
» air «

STEP without
» air «

up- / down preset (Sensor aus) / (sensor off)

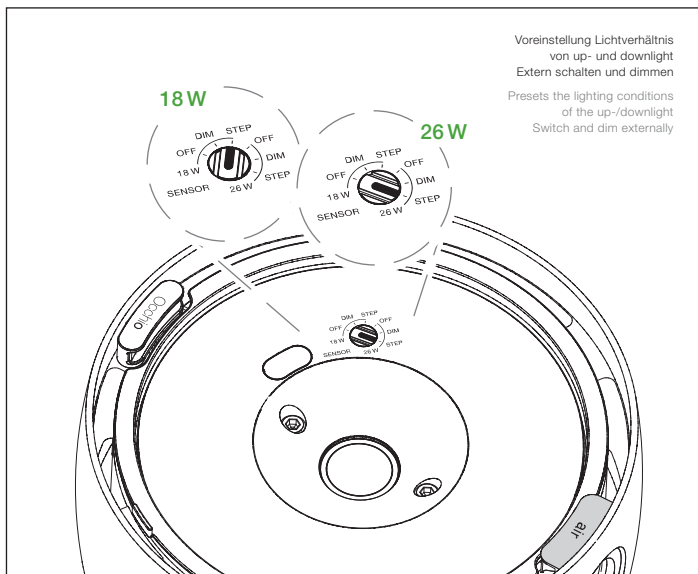

Sensorzone / sensor zone 8 cm

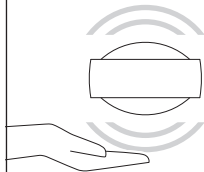

10 Sek. halten / hold for 10 seconds
Leuchte wird entsperrt und blinkt zur Bestätigung /
Luminaire is unlocked and flashes to confirm

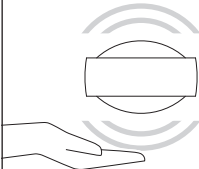

lange halten / keep your hand still for a time
Lichtverhältnis in 5 Stufen einstellen /
Sets the lighting conditions in 5 stages



5 Minuten warten oder netzseitig aus-/einschalten /
Wait for 5 minutes or switch on/off at the mains
Einstellung ist nun gespeichert / The setting is now saved



Schalter / Dimmer*
switch / dimmer*

Schalten und Dimmen / switching and dimming
Leuchte bleibt in der gespeicherten Einstellung /
The saved setting for the luminaire remains unchanged
* dimmen nur mit Occhio Konverter / dimming only with Occhio converter

Steuerung via Occhio air controller (optional)

Control via Occhio air controller (optional)

Occhio air controller

Intuitiv bedienbare Fernbedienung mit vier programmierbaren Tasten (Einrichtung via Occhio air App). Unabhängig von der App können einzelne Leuchten, Gruppen und Szenen gesteuert werden. Optional mit Wandhalterung erhältlich.

Maximaler Bedienkomfort und umfassende Steuerung via Bluetooth 4.0 (Bluetooth Low Energy). Schalten, dimmen, faden, color tune, elektrische Höhenverstellung von einzelnen Leuchten, Gruppen und Szenen.

Occhio air controller

Intuitive remote control with four programmable buttons (setup via Occhio air app). Individual luminaires, groups and scenes can be controlled regardless of the app. Available with optional wall mount.

Maximum ease of use and total control via Bluetooth 4.0 (Bluetooth low energy). Switching, dimming, fading, color tune, electric height adjustment of individual luminaires, groups and scenes.



Zum Einrichten des Occhio air controllers wird die Occhio air App benötigt. Eine Video-Kurzanleitung kann unter: www.occhio.com/air-tutorials aufgerufen werden.

To set up the Occhio air controller, the Occhio air app is required. A video quick start guide can be called up at www.occhio.com/air-tutorials.

schalten/switch

⏏ - ⏏⏏⏏ schalten einzelner Leuchten, Gruppen oder Szenen

⏏ - ⏏⏏⏏ switch individual luminaires, groups or scenes

fading*

⤴ ⤵ fading einzelner Leuchten, Gruppen oder Szenen (up/down Lichtverhältnis einstellen)

⤴ ⤵ fading of individual luminaires, groups or scenes (set up/down light ratio)

dimmen/dim

⊕ ⊖ dimmen einzelner Leuchten, Gruppen oder Szenen

⊕ ⊖ dim individual luminaires, groups or scenes

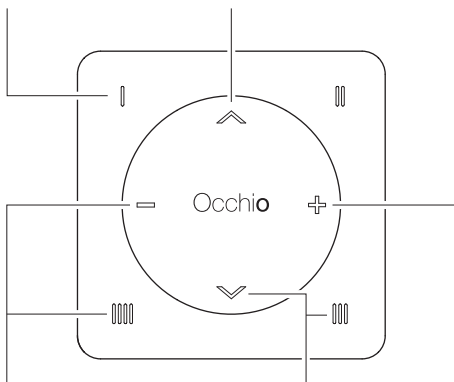

color tune**

⏏ - ⏏⏏⏏ und ⊕ ⊖ Farbtemperatur einzelner Leuchten, Gruppen oder Szenen einstellen

⏏ - ⏏⏏⏏ and ⊕ ⊖ adjust color temperature of individual luminaires, groups or scenes

magic move***

⏏ - ⏏⏏⏏ und ⤴ ⤵ elektrische Höhenverstellung einzelner Leuchten, Gruppen oder Szenen

⏏ - ⏏⏏⏏ and ⤴ ⤵ electronic height adjustment of individual luminaires, groups or scenes

Montage Mounting

Montage inserts / Mounting inserts

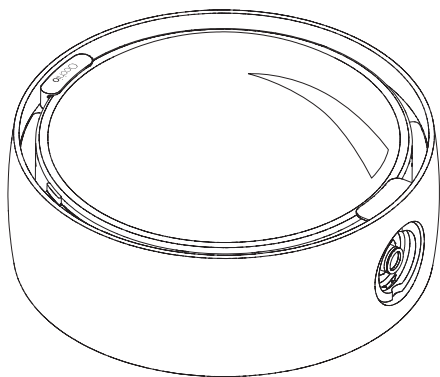

* Nur bei Einstellung 18 W
Only with setting 18 W



Diffusorglas / diffusor glass

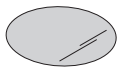

Farbfilter* (optional) /
color filter* (optional)

head

Farbfilter* (optional) /
color filter* (optional)



Diffusorglas / diffusor glass



Version A



Linse / lens



soft edge Glas, satiniertes Glas
oder Farbfilter* (optional) /
soft edge glass, satinised glass
or color filter* (optional)



soft edge Glas, satiniertes Glas
oder Farbfilter* (optional) /
soft edge glass, satinised glass
or color filter* (optional)



Linse / lens



Version D



Diffusorglas / diffusor glass

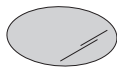

Farbfilter* (optional) /
color filter* (optional)

soft edge Glas, satiniertes Glas
oder Farbfilter* (optional) /
soft edge glass, satinised glass
or color filter* (optional)



Linse / lens



Version E



Montage inserts / Mounting inserts



Achtung!
Leuchte vor allen
Arbeiten min 30 Min.
abkühlen lassen.



Caution
Allow the luminaire
to cool down for at
least 30 min. before
all work.

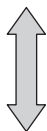

Zum Öffnen drücken.
Push to open.

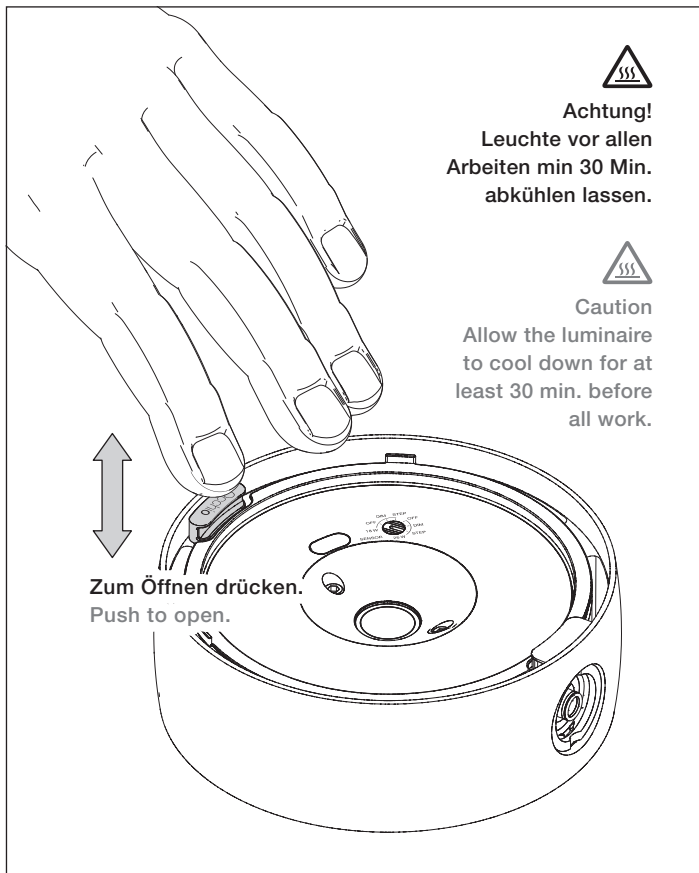



Mehrere inserts gemeinsam einsetzen und auf Hinweise achten!

Use several inserts together and pay attention to notes!

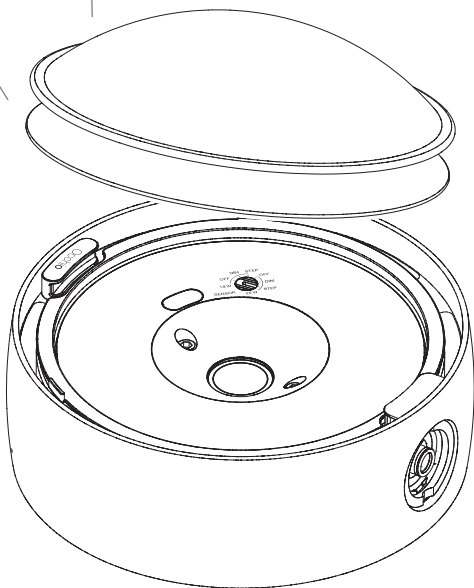

Montage inserts / Mounting inserts

Diffusorglas / diffusor glass



▲ inside

▼ LED

Farbfilter / color filter

Linse / lens

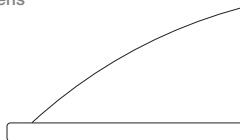

inside ▲

LED ▼

soft edge Glas / soft edge glass

Linse / lens

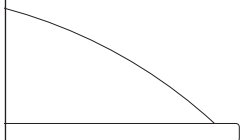

▲ inside

▼ LED

Farbfilter / color filter

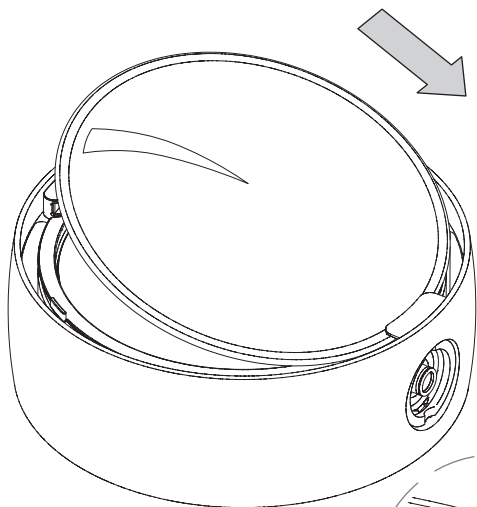

**Feder mit den inserts
leicht eindrücken ...**

**Press the spring with
the inserts slightly in ...**

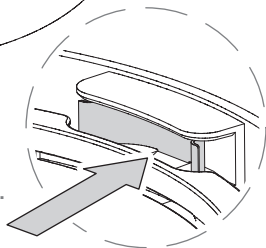

Montage inserts / Mounting inserts

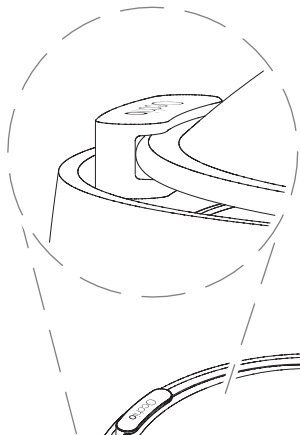

**... und wie abge-
bildet einrasten.**

**... and snap into
place as shown.**

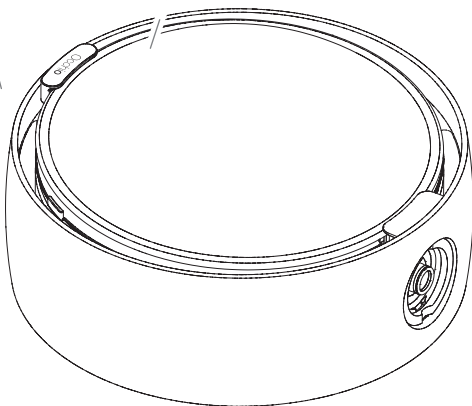



**Die inserts sind nun
fertig montiert.**

**The inserts are com-
pletely mounted.**

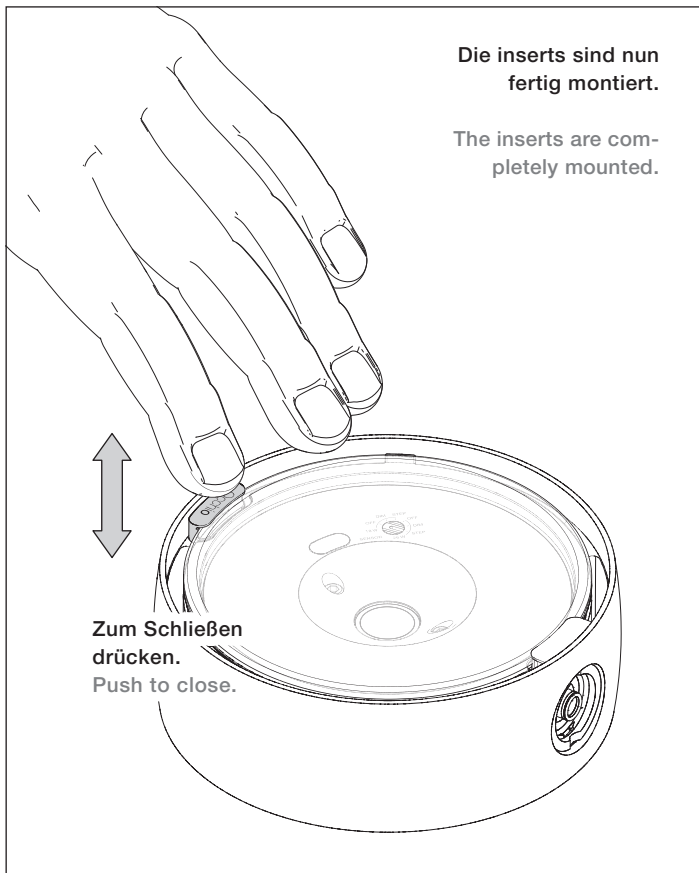

**Zum Schließen
drücken.
Push to close.**

Montage head + body / Mounting head + body



Oberseite /
this side up



head aufstecken und auf die
Ausrichtung achten.

Attach the head and pay
attention to the alignment.

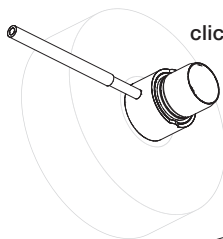

click

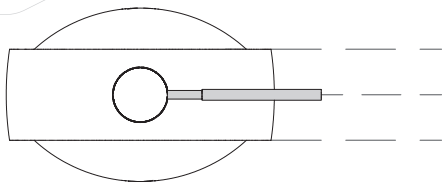
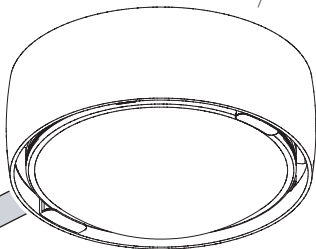



heads müssen gleichen
Typs sein!

heads must be of the
same type!

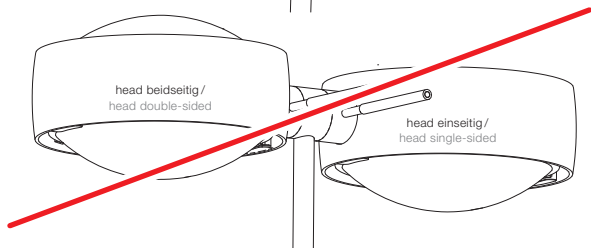
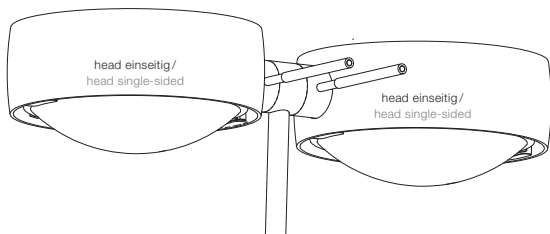
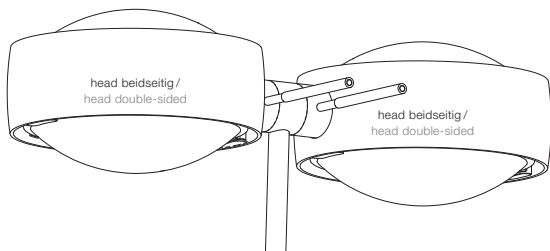

Montage head abnehmen / Mounting remove head

**Karbondrill festhalten, head
drehen bis er sich löst.**

Hold the carbon rod, turn
the head until it releases.

click

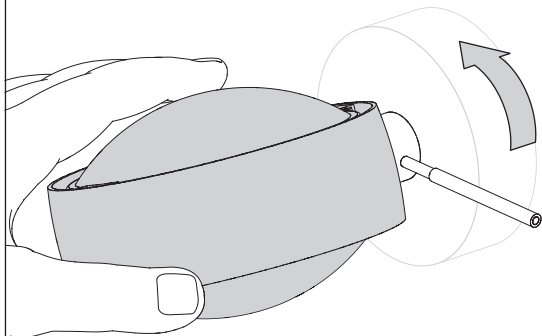



head abnehmen.
remove head.

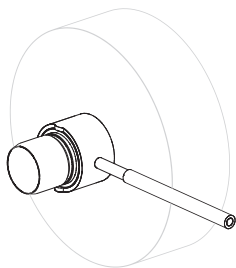
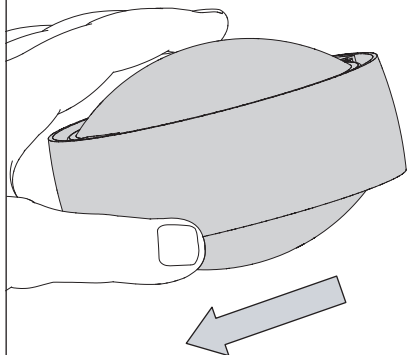

Wechsel Karbongriff /Fixierring Changing carbon rod /fixing ring

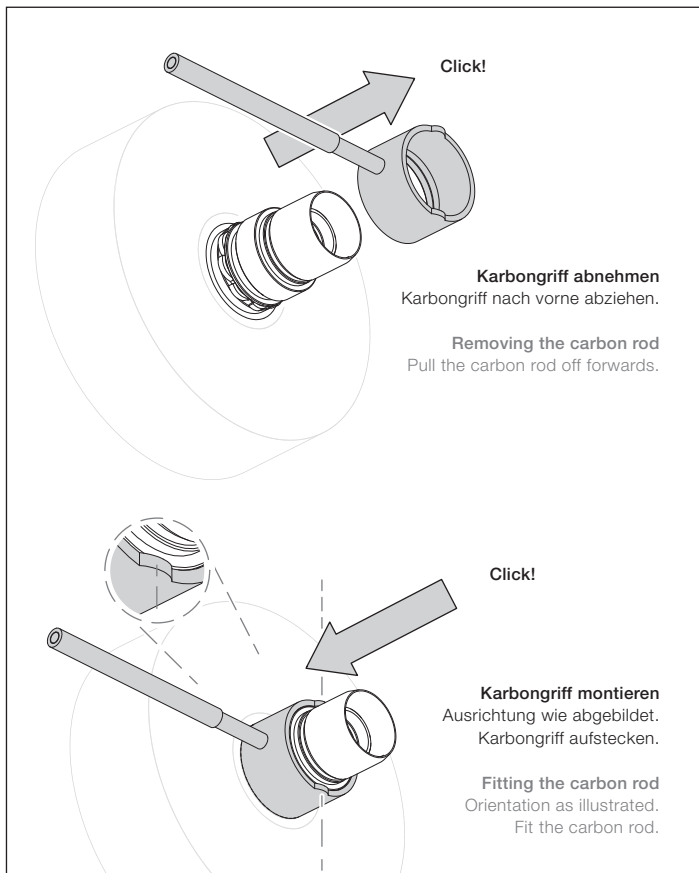

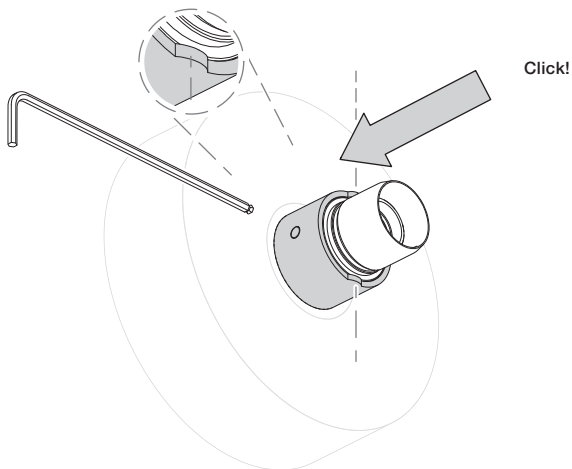
**Fixerring (optional)**

Ausrichtung wie abgebildet. Vor Montage Madenschraube lösen.

Fixerring aufstecken und ggf. mit Sechskantschlüssel gegen Verdrehen sichern.

Fixing ring (optional)

Orientation as illustrated. Before mounting, undo the grub screw.

Fit the fixing ring and, if necessary, secure it against turning using a hexagon key.

Anhang

Appendix

Pflegehinweise

Care instructions

Leuchte nur in abgekühltem Zustand reinigen! Zur Reinigung der Leuchte ein trockenes Mikrofasertuch verwenden. Detaillierte Pflegehinweise sind unter www.occhio.com/de/company/faq zu finden.

Always allow the luminaire to cool down before cleaning! To clean the luminaire, use a dry microfibre cloth. Detailed care instructions are available at www.occhio.com/en/company/faq.

Info & Kontakt

Information & contact

Weitere Fragen beantwortet gerne
Ihr Occhio Fachhändler

Your Occhio specialist retailer will
gladly answer any other questions

www.occhio.com
info@occhio.com

Technische Daten

Technische Daten

Artikelbezeichnung	Sento head beidseitig
Abmessungen	ø 123 mm, H 42 mm (ohne Linse)
Schutzklasse	3
Betriebsspannung	48 V DC, min. 22 W bei 18 W Einstellung, min. 30 W bei 26 W Einstellung
Vorschaltgerät	extern
Dimmung	via head / geeignetem Vorschaltgerät
Material	Aluminium, Stahl verchromt, lackiert oder eloxiert, Kunststoff, Glas, optischer Kunststoff
LED-Leistung	max. 26 W
Zulässige Betriebsbedingung	max. 30°C nur im Innenbereich betreiben
Prüfzeichen	IP 20 CE   

Technische Daten Leuchtmittel





Leuchtmittel	Occhio LED
Ausführung	LED-Chip (wechselbar)
Lebensdauer	> 50.000 Std.

Entsorgung

Bei örtlicher Entsorgungsstelle entsorgen. Der Sento head beidseitig ist recyclebar; RoHS-konform. **Nicht in den Hausmüll geben!**

Technical data

Technical data

Product designation	Sento head double-sided
Dimensions	ø 123 mm, H 42 mm (without lens)
Safety class	3
Supply voltage	48 V DC, min. 22 W for 18 W setting, min. 30 W for 26 W setting
Power supply unit	external
Dimming	via the head / suitable power supply unit
Materials	Aluminium, chrome-plated, painted or anodised steel, plastic, glass, optical plastic
LED power	max. 26 W
Permitted operating conditions	max. 30°C, for indoor use only
Test symbols	IP 20 CE     

Technical data light source

Light source	Occhio LED
Version	LED chip (replaceable)
Life time	> 50.000 Std.

Disposal

Dispose of at a local disposal site. Sento head double-sided is recyclable and RoHS compliant. **Do not dispose of with the household waste!**

Occhio

www.occhio.com



010405944518990610

Occhio

Sento body parete/soffitto singolo

Montageanleitung
Mounting instructions

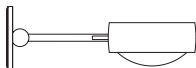
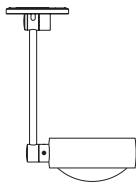

up
flat

Occhio

Sento body parete/soffitto singolo

Montageanleitung

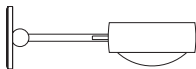
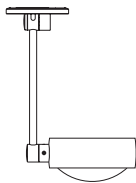

up
flat

De

Inhalt

Sicherheitshinweise	4
Produktbeschreibung	5
Montage body	7
Wechsel Karbongriff/ Fixierring	22
Anhang	23
Informationen	24
Technische Daten	25

Sicherheitshinweise

Lesen Sie die Montage-/Gebrauchsanweisung sorgfältig durch, bevor Sie die Leuchte installieren. Beachten Sie die Sicherheitshinweise in dieser Anleitung genau und bewahren Sie die Anleitung auf.



Dieses Zeichen macht Sie auf eine gefährliche Situation aufmerksam, die eine schwere Verletzung oder den Tod nach sich ziehen kann, wenn sie nicht beachtet wird. Es macht Sie zudem auf mögliche Sachschäden und andere wichtige Informationen in Verbindung mit diesem Produkt aufmerksam.



Die Montage von Elektrokomponenten darf nur von qualifiziertem Fachpersonal durchgeführt werden. Reparaturarbeiten dürfen nur von autorisiertem Fachpersonal oder dem Hersteller durchgeführt werden. Vor allen Arbeiten am Strahler (Installation, Leuchtmittelwechsel, Reinigung etc.) diesen unbedingt vom Stromnetz trennen.



Dieses Zeichen macht Sie auf Situationen aufmerksam, bei denen Sie direkt in das Licht der LED blicken könnten. Dies kann zu Nachbildern und bei längerer Dauer zu Schädigungen der Augen führen.



Sicherheitsabstand zu brennbaren Objekten einhalten: 20 cm!



Dieses Zeichen macht Sie auf heiße Oberflächen aufmerksam, deren Berührung Verbrennungen zur Folge haben können.

Achtung: Die Oberfläche des Strahlers kann nach längerer Betriebsdauer heiß sein! Vor allen Arbeiten am Strahler (Montage des Strahlers, Wechsel des Leuchtmittels, Wechsel der Inserts, usw.), Strahler immer ausschalten und mindestens 30 Minuten abkühlen lassen. Nur zur Installation außerhalb des Handbereichs vorgesehen.

Produktbeschreibung

Modulares LED-Kopf-Körper-System ermöglicht freie Kombination verschiedener Oberflächen von head, body und base.

Head für Konfiguration und Wartungszwecke abnehmbar, LED wechselbar. Heads mit einseitigem oder beidseitigem Lichtaustritt erhältlich, Lichtleistung 18W oder 26W.

Lichtwirkung über optionale inserts veränderbar, dichroitische Farbfilter zusätzlich einsetzbar.

Verstellmöglichkeit über wärmeentkop-pelten Karbongriff. Head optional gegen Verdrehen fixierbar.

up-Version

LED Wandleuchte mit hoher base inkl. Vorschaltgerät (Konverter) für Montage auf fester Wand, Anschluß an 230V.

Extern dimmbar per Phasenabschnitt-dimmer oder über Gestensteuerung »touchless control« am head.

flat-Version

LED Wandleuchte mit flacher base für Montage auf Hohlraumdose, Anschluß an externe Konstantspannungsquelle (Konverter).

Extern dimmbar (abhängig vom Vorschaltgerät) oder über Gestensteuerung »touchless control« am head.

Montage body

Sento parete/soffitto singolo up

für feste Decke/Wand



9

Sento parete/soffitto singolo flat

für Hohlraum-/Einputzdose

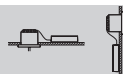

17

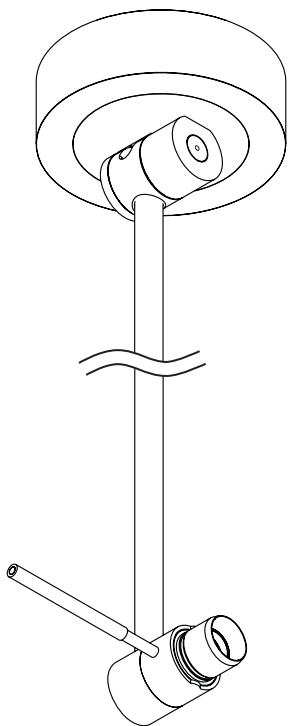

Sento parete/soffitto singolo up



230V AC
Netzanschlussleitung



Montageplatte

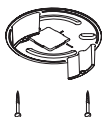

Occhio Konverter



body mit
Montageplatte

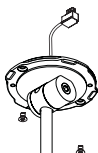

Cover

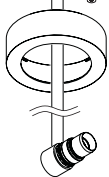

Karbongriff



Fixierring
(optional)

Installation

230V AC
Netzanschlussleitung

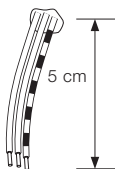

Netzkabel auf 5cm ablängen und Enden abisolieren.

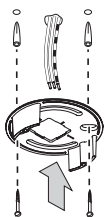

Montageplatte über den Stromauslass an Decke/Wand setzen und so drehen, dass die Langlöcher die gewünschte Ausrichtung haben. Positionen der Bohrlöcher anzeichnen. Bei Wandmontage Gewindelöcher senkrecht ausrichten!

Wandmontage:
Gewindelöcher senkrecht ausrichten!

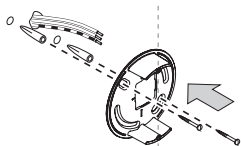

Auf den Verlauf von Stromleitungen achten!

Zwei Löcher \varnothing 6 mm bohren, Dübel bündig einsetzen und Montageplatte anschrauben (Schrauben und Dübel sind im Lieferumfang enthalten). Darauf achten, dass die Schrauben bündig mit der Montageplatte abschließen.

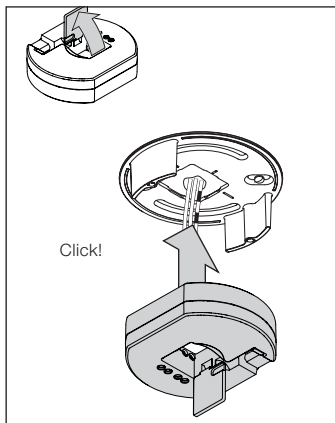

Klappe in der Mitte des Converters öffnen.

Konverter bündig in die Montageplatte einrasten.

Dabei die Enden der Netzleitung durch die Öffnung des Converters führen.

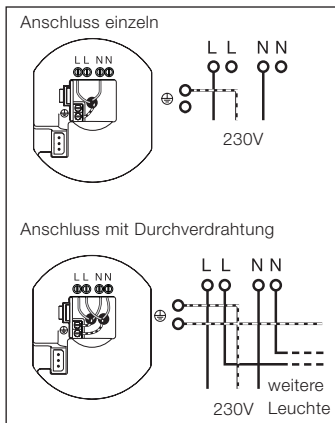

Kabelenden der Netzleitung nach Schema an die Klemmen des Converters anschließen.



Achtung!
Vor der Montage alle stromführenden Leitungen vom Stromnetz trennen!

Installation

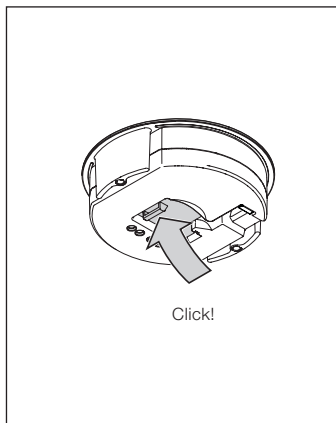

Klappe des Konverters schließen.

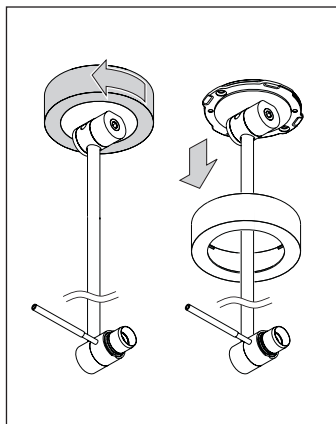

Cover entgegen dem Uhrzeigersinn lösen und auf dem Leuchtenarm hängen lassen.

Schutzfolie noch nicht entfernen!

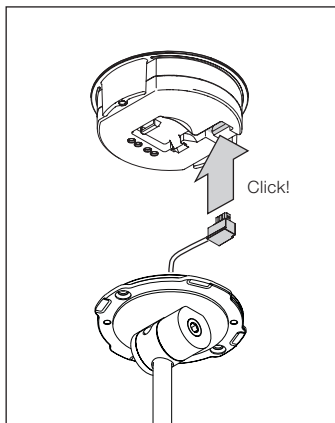

Stecker des Leuchtenkörpers in die Buchse des Converters stecken.

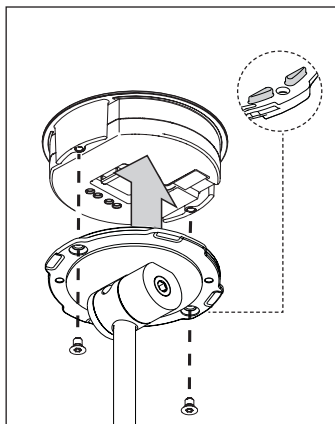

Kabel in die Ausparung des Converters legen – nicht einklemmen!

Leuchtenkörper mit mitgelieferten Schrauben (Inbus) auf beide Abstandhalter der Montageplatte schrauben.

Dabei darauf achten, dass die Rastnasen des Leuchtenkörpers (siehe Detail) bündig auf den Abstandshaltern aufliegen.

Installation

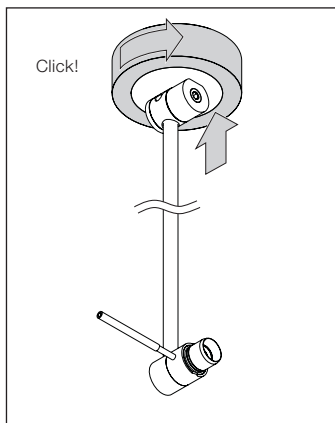

Schutzfolien entfernen

Cover vorsichtig über den Leuchtenarm führen.

Im Uhrzeigersinn drehen und arretieren.

Der body ist nun fertig montiert.
Montage head: Siehe Anleitung head.

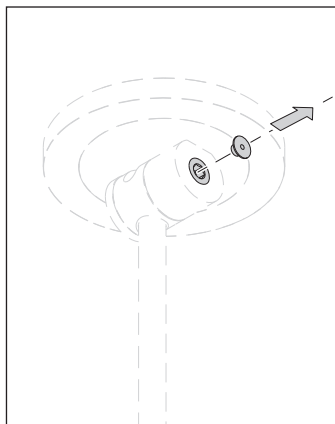

Zu Revisionszwecken entnehmbar.
(nur bei weißem und schwarzem body).

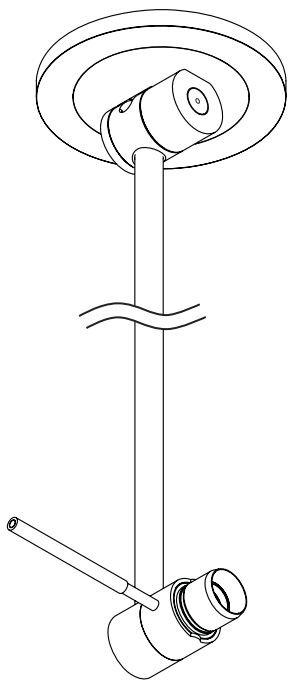

Sento parete/soffitto singolo flat

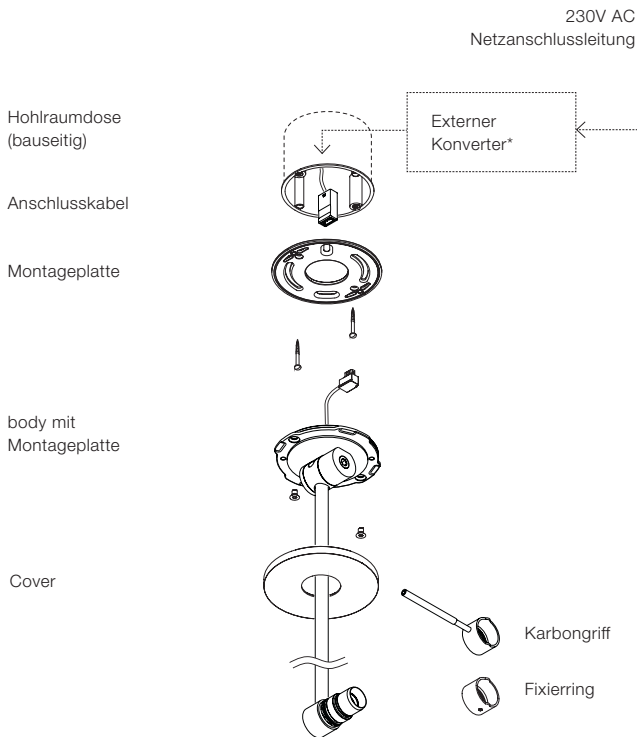

* Externer LED Konverter (Gleichspannungsquelle)
48V DC, min. 30 W

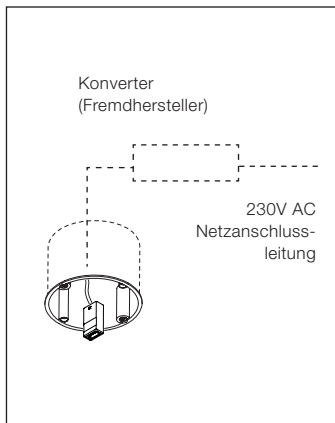
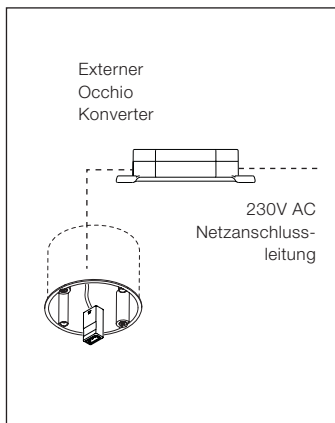

Externen Occhio Konverter anschließen:

Konverter fachgerecht an die Netzleitung anschließen.
Buchse des LED-Anschlusskabels durch die Hohlraum-/Einputzdose nach außen führen.

Konverter eines Fremdherstellers anschließen (siehe Beiblatt zum Konverter):

Konverter nach Schema an die Netzleitung anschließen.
Kabel mit LED-Buchse an den Konverter anschließen.
Technische Hinweise des jeweiligen Herstellers beachten!

**Schwarz = Pluspol,
Weiß = Minuspol**

Buchse des LED Verlängerungskabels durch die Hohlraum-/Einputzdose nach außen führen.



Achtung!
Vor der Montage alle stromführenden Leitungen vom Stromnetz trennen!

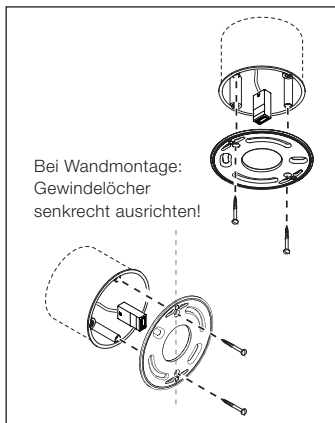

Montageplatte an die Hohlraumdo-
se schrauben. Dabei die Buchse
des LED-Anschlusskabels durch
die Öffnung führen.

Darauf achten, dass die Schrau-
ben bündig mit der Montageplatte
abschließen.

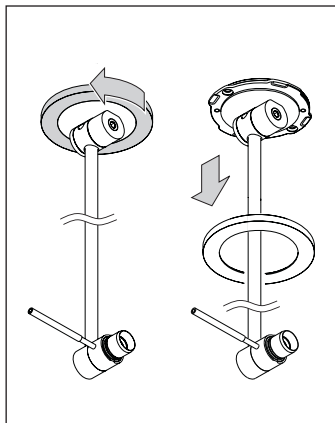

Cover entgegen dem Uhrzeiger-
sinn lösen und auf dem Leuchten-
arm hängen lassen.

Installation

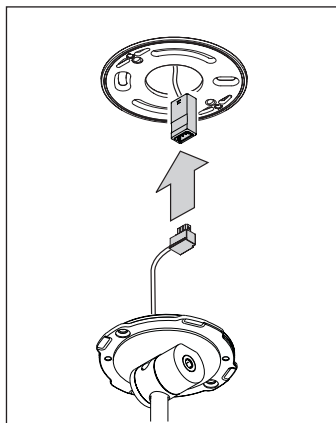

Stecker des bodies mit der Buchse des LED-Anschlusskabels verbinden.

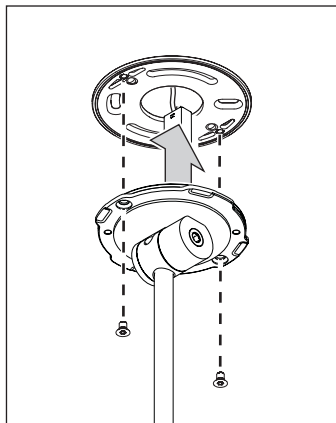

Kabel mit Steckverbindung in den Hohlraum zurückführen.

Leuchtenkörper mit mitgelieferten Schrauben (Inbus) auf die Montageplatte schrauben.

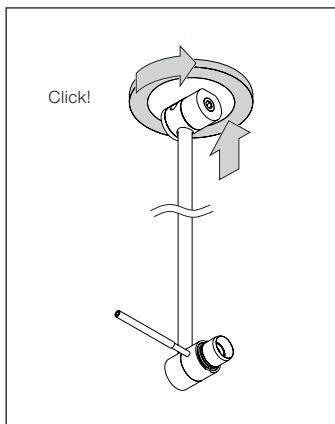

Schutzfolien entfernen.

Cover vorsichtig über den Leuchtenarm führen.

Im Uhrzeigersinn drehen und arretieren.

Der body ist nun fertig montiert.
Montage head: Siehe Anleitung head.

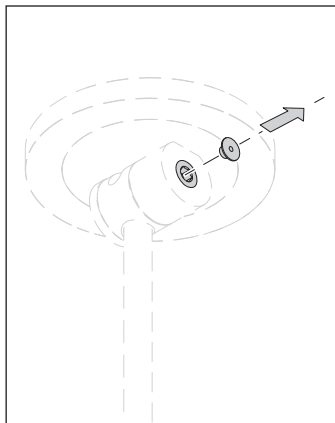

Zu Revisionszwecken entnehmbar.
(nur bei weißem und schwarzem body).

Wechsel Karbongriff/Fixierring

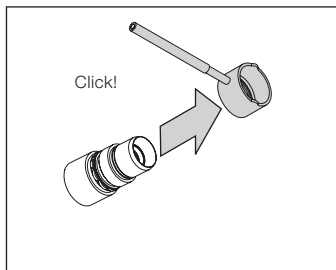

Karbongriff abnehmen

Karbongriff nach vorne abziehen.

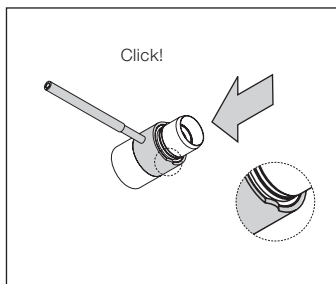

Karbongriff montieren

Ausrichtung wie abgebildet.

Karbongriff aufstecken.

Der body ist nun fertig montiert.
Montage head: Siehe Anleitung head.

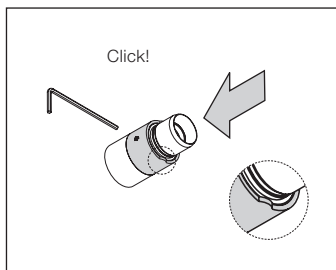

Fixierring (optional)

Ausrichtung wie abgebildet. Vor Montage Madenschraube lösen. Fixierring aufstecken und ggf. mit Sechskantschlüssel gegen Verdrehen sichern. Der body ist nun fertig montiert.
Montage head: Siehe Anleitung head.

Anhang

Pflegehinweise

Leuchte nur in abgekühltem Zustand reinigen!

Zur Reinigung der Leuchte ein trockenes Mikrofasertuch oder das Occhio Reinigungsmittel verwenden.

Info & Kontakt



Weitere Fragen beantwortet gerne
Ihr Occhio Fachhändler

www.occhio.de

info@occhio.de

Technische Daten

Technische Daten Leuchte

Artikelbezeichnung	Occhio Sento soffitto singolo
up Version	head ø123mm, base ø88mm, H29mm
flat Version	head ø123mm, base ø88mm, H8mm
Länge	300 / 400 / 600 / 800mm
Drehbereich head	360° ohne Anschlag
Schwenkbereich body	300-600mm 120° / 800mm 90°
Drehbereich body (optional)	180° mit Anschlag
Schutzklasse	up Version: 2 flat Version: 3
Anschluss	up Version: 230V AC, 50Hz flat Version: 48V DC, min. 22W pro 18W head, min. 30W pro 26W head
Vorschaltgerät	up Version: integriert flat Version: extern
Dimmung	über im Kopf integrierten »touchless Sensor« oder: up Version: per Phasen- abschnittdimmer (Liste kompatibler Dim- mer: www.occhio.de/dim) flat Version: mit geeignetem Vorschaltgerät
Material	Leuchte: Aluminium, Stahl verchromt, lackiert oder eloxiert, Kunststoff inserts: Glas, optischer Kunststoff
Leuchtmittel	Occhio LED
LED Leistung	18W / 26W je nach head
Zulässige Betriebsbedingung	max. 30°C (nur im Innenbereich betreiben)
Prüfzeichen	IP 20 CE   up:  flat: 
Entsorgung	Bei örtlicher Entsorgungsstelle entsorgen. Das Vorschaltgerät und der head sind recyclebar; RoHS-konform. Nicht in den Hausmüll geben!

Occhio

Sento body parete/soffitto singolo

Mounting instructions

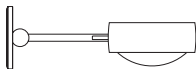
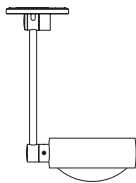

up
flat

En

Contents

Safety precautions	4
Product description	5
Assembling the body	7
Changing the carbon rod/ fixing ring	22
Appendix	23
Information	24
Technical data	25

Safety precautions

Read through the mounting/use instructions carefully before installing the luminaire. Follow the safety precautions in these instructions closely and keep the instructions in a safe place.

Explanation of symbols



This symbol warns you of a dangerous situation which could lead to serious injury or even death if the instructions are not observed. It also draws your attention to possible material damage and provides other important information in connection with this product.



This symbol warns you of hot surfaces, which could cause burns if touched.



This symbol draws your attention to situations in which you could look directly into the light of the LED. This may cause an after-image effect and may result in damage to the eyes if you look at the light directly for prolonged periods.

General safety precautions



The assembly and installation of electrical components must be carried out only by qualified personnel. Repairs must be carried out only by authorised, qualified personnel or the manufacturer. Before performing any work on the spotlight (installation, changing the light source, cleaning, etc.), it must be disconnected from the mains supply.



Maintain the minimum safety distance from flammable materials: 20 cm.



Caution: When used for prolonged periods, the surface of the spotlight can become hot. Before performing any work on the spotlight (fitting the spotlight, changing the light source or insert, etc.), always switch the spotlight off and let it cool for at least 30 minutes.

Product description

Thanks to the modular LED head/body system, it is possible to combine a head, body and base each with different surfaces.

The head can be taken off for configuration and maintenance; replaceable LED. Heads with single-sided or double-sided light output are available; luminous power 18 W or 26 W.

Lighting effect can be changed through optional inserts; dichroitic colour filter can be additionally inserted.

Adjustable thanks to the heat-insulated carbon rod. As an option, the head can be secured against turning.

up-Version

LED wall-mounted luminaire with high base incl. power supply unit (converter) for mounting on a solid wall; connection to 230 V.

Externally dimmable by trailing-edge phase-cut dimmer or by gesture-controlled „touchless control“ on the head.

flat-Version

LED wall-mounted luminaire with flat base for mounting on a hollow ceiling box; connection to an external constant-voltage source (converter).

Externally dimmable (depending on power supply unit) or by gesture-controlled „touchless control“ on the head.

Assembling the body

Sento parete/soffitto singolo up

for solid ceilings/walls



9

Sento parete/soffitto singolo flat

for hollow ceiling/plastering box

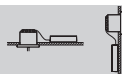

17

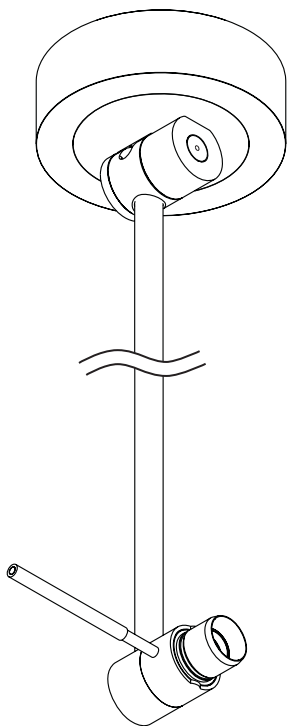

Sento parete/soffitto singolo up



230 V AC
mains cable



Mounting plate

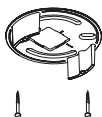

Occhio converter



Body with
mounting plate

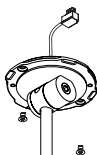

Cover

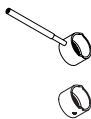
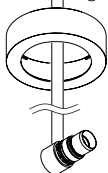

Carbon rod

Fixing ring
(optional)

Installation

230 V AC
mains cable

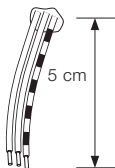

Cut the mains cable to a length of 5 cm and strip the insulation from the ends.

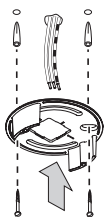

Place the mounting plate over the power outlet and against the ceiling/wall, and turn it until the elongated holes are aligned as required. Mark the positions where the holes are to be drilled. When mounting to a wall, orient the threaded holes vertically.

Check the routing of the power cables.

Wall mounting:
Orient the threaded
holes vertically.

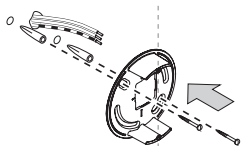

Drill two 6 mm diameter holes, push in the rawlplugs so that they lie flush and screw on the mounting plate (screws and rawlplugs are included in the scope of delivery).

Ensure that the screws finish flush with the mounting plate.

Sento parete/soffitto singolo up

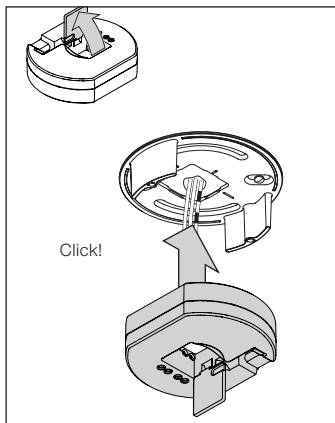

Open the flap in the centre of the converter.

Lock the converter into the mounting plate so that it is fitted flush.

At the same time, guide the ends of the mains cable through the converter opening.

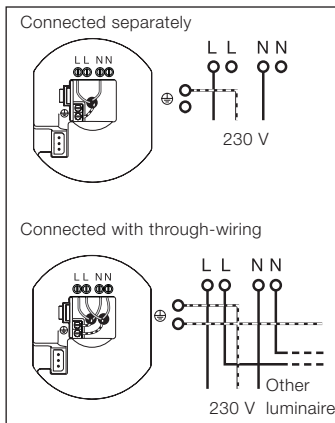

Connect the ends of the mains cable to the converter terminals in accordance with the diagram.



Caution:
Before fitting, disconnect all current-carrying lines from the mains supply.

Installation

Close the flap of the converter.

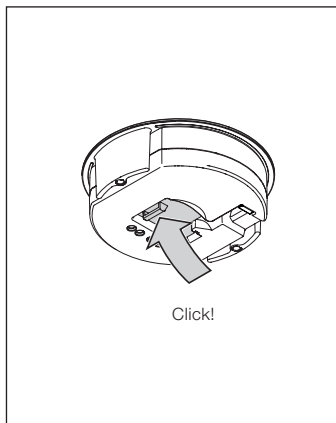

Undo the cover by turning it anti-clockwise and let it hang on the luminaire stem.

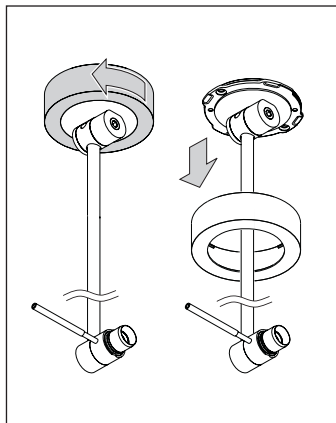

Do not remove the protective film yet.

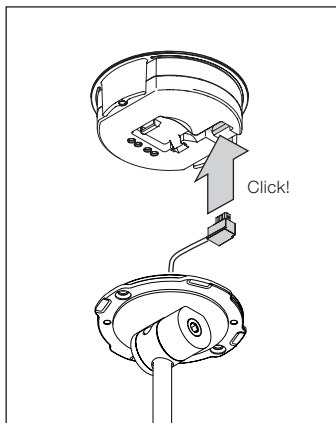

Insert the plug of the luminaire body into the socket of the converter.

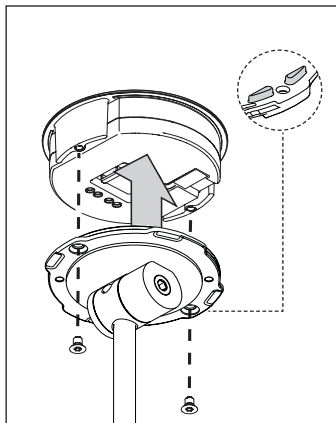

Lay the cable in the recess of the converter. Do not trap the cable.

Screw the luminaire body onto the two spacers of the mounting plate using the screws (Allen) provided.

When doing so, ensure that the snap tabs on the luminaire body (see detail) rest flush on the spacers.

Installation

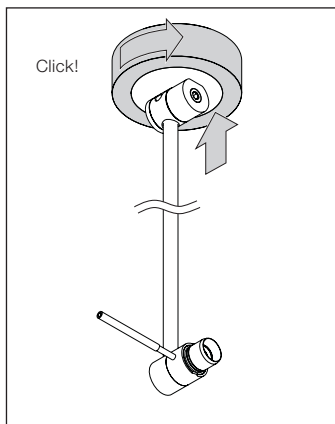

Removing the protective film

Carefully guide the cover over the luminaire stem.

Turn clockwise and lock in place.

The body is now fully assembled. To assemble the head: See „Assembling the head“.

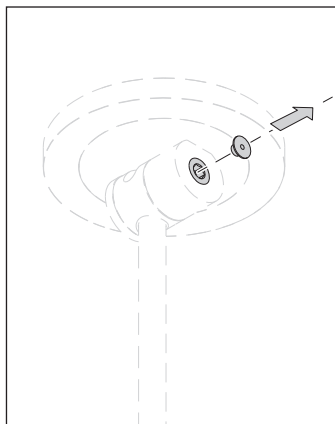

For inspection purpose removable (only for white and black body).

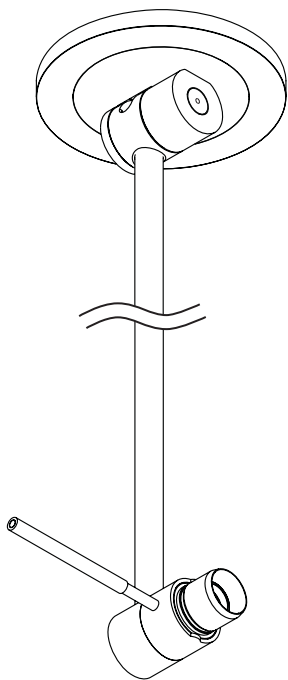

Sento parete/soffitto singolo flat



Hollow ceiling box
(provided and fitted by
customer)

Connection cable

Mounting plate

Body with
mounting plate

Cover

230 V AC
mains cable

External
converter*

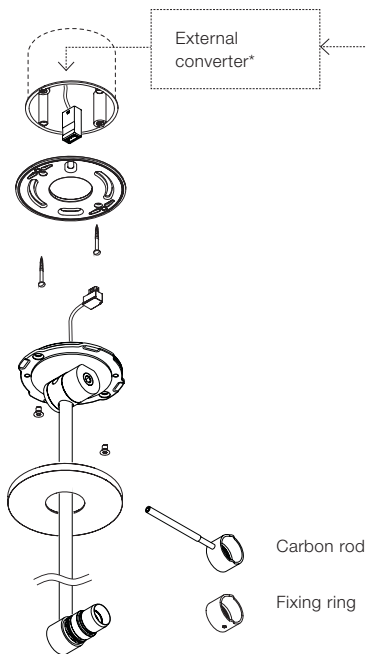

* External LED converter (DC voltage source)
48 V DC, min. 30 W

Installation

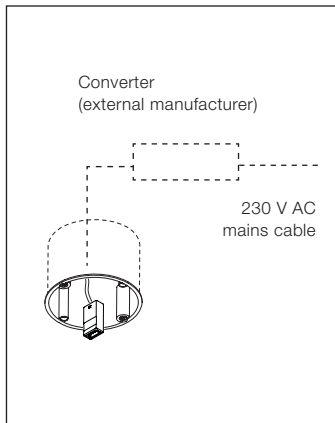
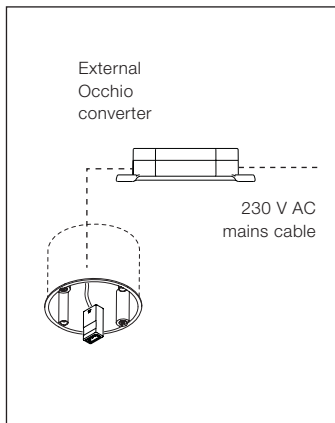

To connect an external Occhio converter:

Correctly connect the converter to the mains cable.

Guide the socket of the LED connection cable to the outside through the hollow ceiling/plastering box.

Connecting a converter from an external manufacturer (see supplementary sheet for the converter):

Connect the converter to the mains cable as shown in the wiring diagram. Connect the cable with the LED socket to the converter. Observe the technical instructions of the particular manufacturer.

**Black = positive pole,
white = negative pole**

Guide the socket of the LED extension cable to the outside through the hollow ceiling/plastering box.



Caution:

Before fitting, disconnect all current-carrying lines from the mains supply.

Sento parete/soffitto singolo flat

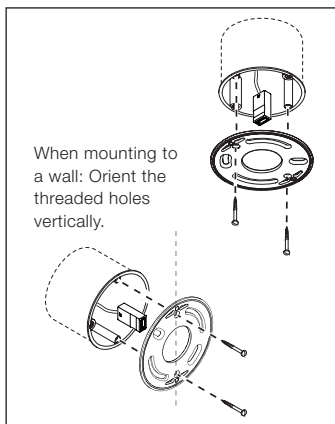

Screw the mounting plate to the hollow ceiling box. As you do so, guide the socket of the LED connection cable through the opening.

Ensure that the screws finish flush with the mounting plate.

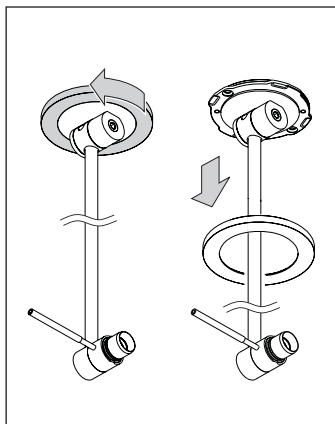

Undo the cover by turning it anti-clockwise and let it hang on the luminaire stem.

Installation

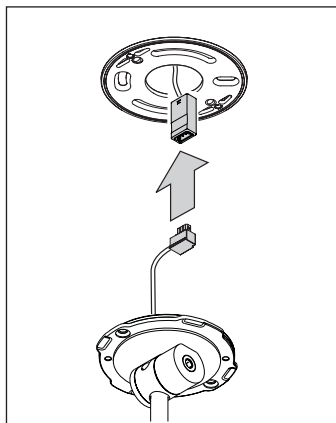

Connect the plug of the body to the socket of the LED connection cable.

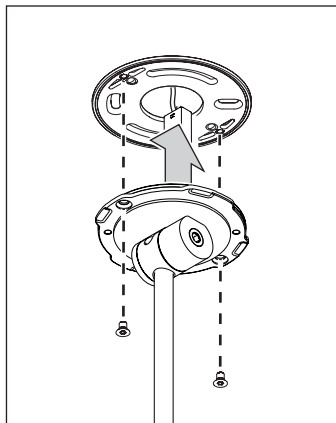

Guide the cable with the plug connection back into the hollow ceiling box.

Screw the luminaire body onto the mounting plate using the screws (Allen) provided.

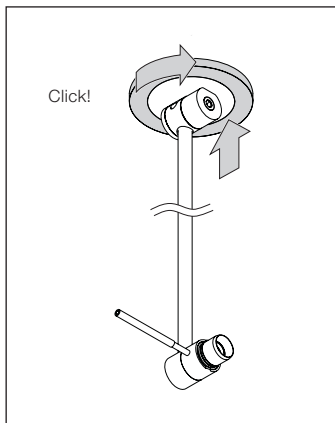

Remove the protective film.

Carefully guide the cover over the luminaire stem.

Turn clockwise and lock in place.

The body is now fully assembled.
To assemble the head: See „Assembling the head“.

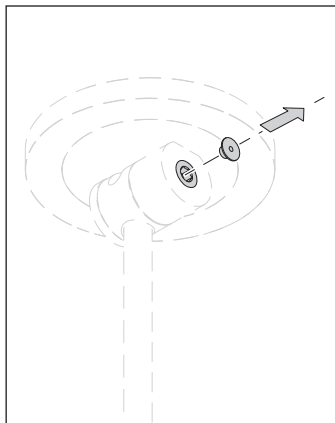

For inspection purpose removable
(only for white and black body).

Wechsel Karbongriff/Fixierring

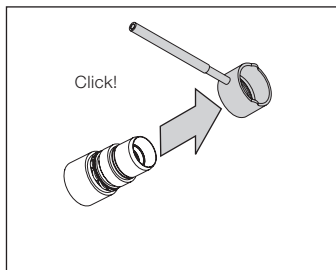

Removing the carbon rod

Pull the carbon rod off forwards.

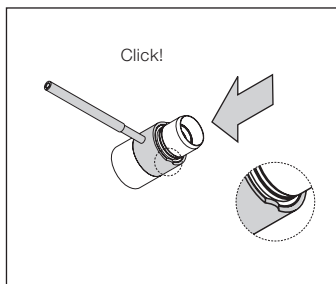

Fitting the carbon rod

Orientation as illustrated.

Fit the carbon rod.

The body is now fully assembled.
To assemble the head: See „Assembling the head“.

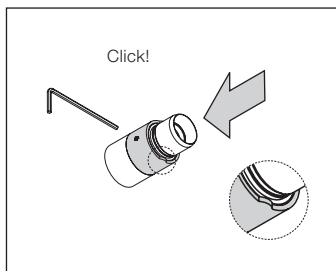

Fixing ring (optional)

Orientation as illustrated. Before mounting, undo the grub screw. Fit the fixing ring and, if necessary, secure it against turning using a hexagon key. The body is now fully assembled.

To assemble the head: See „Assembling the head“.

Appendix

Care instructions

Always allow the luminaire to cool down before cleaning.

To clean the luminaire, use a dry microfibre cloth or the Occhio cleaning agent.

Information & contact

Your Occhio specialist retailer will gladly answer any other questions

www.occhio.de

info@occhio.de

Technical data

Technical data – luminaire

Product designation	Occhio Sento soffitto singolo
up version	Head dia. 123 mm, base dia. 88 mm, H 29 mm
flat version	Head dia. 123 mm, base dia. 88 mm, H 8 mm
Length	300 / 400 / 600 / 800 mm
Head turning range	360° without stop
Head swivel range	300-600 mm 120° / 800 mm 90°
Body turning range (optional)	180° with stop
Safety class	up version: 2 flat version: 3
Connection	up version: 230 V AC, 50 Hz flat version: 48 V DC, min. 22 W per 18 W head, min. 30 W per 26 W head
Power supply unit	up Version: Integrated flat Version: External
Dimming	Via »touchless sensor« integrated in the head or: up version: by trailing-edge phase-cut dimmer (for a list of compatible dimmers, visit www.occhio.de/dim) flat version: With suitable power supply unit
Materials	Luminaire: Aluminium, chrome-plated, painted or anodised steel, plastic Inserts: Glass, optical plastic
Light source	Occhio LED
LED power	18 W/26 W depending on the head
Permitted operating conditions	Max. 30°C (for indoor use only)
Test symbols	IP 20    up:  flat: 
Disposal	Dispose of at the local waste disposal site. The power supply unit and the head are recyclable and RoHS-compliant. Do not dispose of with household waste.

Occhio

www.occhio.com



010404295672971610